

# **OPERATOR MANUAL**

## **. Solis 50 STAGE V**

**INTERNATIONAL TRACTORS LIMITED**

**HOSHIARPUR (INDIA)**

Phno 91-1882-302-525/526/526

Part Number : 300344321A

Publication No. : STGV/AUG21/07

Revision: 00



## PREFACE

Dear Customer,

We welcome you with great pleasure for joining ITL family and thanks for faith and trust you have placed in the careful selection of your tractor

We are sure that our dealer must have taken good care while delivering tractor upto your satisfaction.

Before using tractor, it is recommended to read this manual thoroughly. Any person who uses the tractor should be also advised to read these instructions.

Daily and routine maintenance operations can be easily performed with the use of this manual. To get best and trouble free performance from you tractor. Please ensure for periodic maintenance as per recommended schedule in the owner's manual at authorized dealership.

Use only genuine ITL spare parts from dealer/stockist for reliable and durable performance.

Information provided in this operator manual is accurate at the time of printing. Improvements and modifications are a continuous process at **International Tractors Limited (ITL)** , therefore ITL reserves the right for modification at any time without prior notice.

For any help/support feel free to call our dealership with the tractor details like Engine number and Chassis number.

We wish you prosperity and growth.

International Business (IB)

### **International Tractors Limited (ITL)**

Vil.-Chaik Gujran,P.O. Piplanwala 146022

Jalandhar Road, Hoshiapur, Punjab, India.

Phone: 91-1882-302-525/526/526

E-mail:exports@sonalika.com

This publication has been written in compliance with International Standard ISO 3600 'Guide for information, contents and presentation of operation and maintenance manuals supplied with tractors and machinery for agricultural and forestry use.



# OWNERSHIP AND TRACTOR DETAILS

<b>OWNER'S NAME &amp; ADDRESS</b>	
-----------------------------------	--

Model:	Delivery Date :
Chassis No. :	Bill No. / Date :
Engine No. :	Alternator Make / Sr. No. :
Battery Make / Sr. No. :	Starter Motor Make / Sr. No. :
FIP Sr. No. :	Hydraulic Pump Make / Sr. No. :

Tyre	Make	Size	Sr.No
Front (left)			
Front (left)			
Rear (Left)			
Rear (Right)			

I have understood all the terms & conditions of the maintenance of the tractor, terms of warranty, systems, Scheduled services & understood operation of tractor in the field and other operations.  
 Received a new defect free tractor Chassis No. ....  
 ..... Engine No. ....  
 ..... & fully satisfied with the transaction.

<b>OWNER'S SIGNATURE</b>	<b>DEALER STAMP &amp; SIGNATURE</b>
	<b>PH NO:</b> ..... <b>DATE:</b> .....

**\* IMPORTANT INFORMATION TO CUSTOMER:** For any assistance with regard to our product, please contact our authorized dealer or authorized service center.



# OWNERSHIP AND TRACTOR DETAILS

<b>OWNER'S NAME &amp; ADDRESS</b>	
-----------------------------------	--

Model:	Delivery Date :
Chassis No. :	Bill No. / Date :
Engine No. :	Alternator Make / Sr. No. :
Battery Make / Sr. No. :	Starter Motor Make / Sr. No. :
FIP Sr. No. :	Hydraulic Pump Make / Sr. No. :

Tyre	Make	Size	Sr.No
Front (left)			
Front (left)			
Rear (Left)			
Rear (Right)			

I have understood all the terms & conditions of the maintenance of the tractor, terms of warranty, systems, Scheduled services & understood operation of tractor in the field and other operations.  
 Received a new defect free tractor Chassis No. ....  
 ..... Engine No. ....  
 ..... & fully satisfied with the transaction.

<b>OWNER'S SIGNATURE</b>	<b>DEALER STAMP &amp; SIGNATURE</b>
	<b>PH NO:</b> ..... <b>DATE:</b> .....

**\* IMPORTANT INFORMATION TO CUSTOMER:** For any assistance with regard to our product, please contact our authorized dealer or authorized service center.





# TABLE OF CONTENTS

---

1 Introduction & Tractor Identification.....	1-15
1.1 Using this Operator Manual .....	1-15
Tractor Identification — Platform .....	1-16
1.2 Chassis Serial Number (A) Platform .....	1-16
1.3 Engine Serial Number (B) Platform.....	1-16
1.4 Statutory Plate (C) Platform .....	1-16
1.5 ROPS Certificate Plate (D) Platform .....	1-16
Tractor Identification — Cabin.....	1-17
1.2 Chassis Serial Number (A) Cabin.....	1-17
1.3 Engine Serial Number (B) Cabin.....	1-17
1.4 Statutory Plate (C) Cabin .....	1-17
1.5 Cabin Plate (D) .....	1-17
1.6 Universal Symbols.....	1-18
2 Warranty & Safety Notes.....	2-19
2.1 Introduction .....	2-19
2.2 Warranty, Pre—delivery and Installation.....	2-20
2.3 Warranty Procedure .....	2-20
2.4 Parts Warning.....	2-20
2.5 If You Move .....	2-21
2.6 Service After Warranty.....	2-21
2.7 Safety .....	2-21
2.8 Safety Alert Symbols and Terms .....	2-22
2.9 Safety: Introduction .....	2-22
2.10 Safety: A word to the Operator .....	2-23
2.11 Safety: Danger, Warning and Caution .....	2-23
2.12 Safety: Decals.....	2-24
2.13 Safety: Follow A Safety Program.....	2-24
2.14 Safety Frame .....	2-25
2.15 Safety: Prepare For Safe Operation.....	2-26
2.16 Know Your Equipment: .....	2-27

## TABLE OF CONTENTS

---

2.17 Use all Available Protective Devices .....	2-28
2.18 Check the Tractor .....	2-28
2.19 Clean the tractor .....	2-29
2.20 Protect the environment .....	2-30
2.21 Safety: Servicing The Tractor.....	2-30
2.22 Safety: Starting .....	2-31
2.23 Follow recommended starting procedures .....	2-32
2.24 Safety: Work Safety.....	2-33
2.25 Make the right moves .....	2-33
2.26 Follow safe operating practices .....	2-34
2.27 Watch out for others .....	2-34
2.28 Risk of overturning .....	2-35
2.29 To avoid side overturns .....	2-36
2.30 To avoid rear overturns .....	2-37
2.31 General operating hazards .....	2-40
2.32 Road Transport .....	2-41
2.33 Road regulations .....	2-42
2.34 Safety-After Operation .....	2-42
2.35 Risks deriving from exposure to noise .....	2-43
2.36 Safely Handling Batteries .....	2-45
2.37 Handle fuel with care .....	2-46
2.38 Avoid Hot Exhaust.....	2-46
2.39 PTO Safety.....	2-47
2.40 Safety while Operating Loader attachments.....	2-50
2.41 Avoid contact with Agricultural Chemicals .....	2-51
2.42 Limited Use in Forestry Operation .....	2-51
2.43 Safety from Lightning Strike.....	2-51
2.44 Noise & Vibration Levels .....	2-52
2.45 Safety Labels & its Position on Tractor .....	2-52
3 Instruments And Controls .....	3-58

# TABLE OF CONTENTS

---

3.1 Tractor Controls (Platform/Cabin Tractor) .....	3-58
3.2 Instrument Panel .....	3-59
3.3.a Dashboard Controls (Platform/Cabin Tractor) .....	3-68
3.3.b RH Fender Mounted Controls Switch (Platform Tractor) .....	3-68
3.3.c RH Fender Mounted Controls Switch (Cabin Tractor) .....	3-69
3.3.d Roof Mounted Switch (Cabin Tractor) .....	3-69
3.4 Roof Mounted Switches for Cabin Tractor .....	3-73
3.5 Ignition (Starting) Switch .....	3-74
Roof Mounted Interior for Cabin Tractor .....	3-75
3.6 Fuse Boxes for Platform and Cabin .....	3-79
3.6.1 Fuse Boxes for Cabin Tractor .....	3-79
3.6.2 Fuse Boxes for Platform Tractor .....	3-80
3.7 Combination Switch (Lighting, Turn Signals, Horn Control Lever) .....	3-81
3.8 DPF System .....	3-82
3.9 Battery .....	3-84
3.10 Seven Pin Rear Socket for Trailer .....	3-84
3.11 Three Pin Rear Socket .....	3-84
3.12 Registration Plate (B) .....	3-85
3.13 Tool Box (C) .....	3-85
3.14 USB Socket (D) .....	3-85
3.15 Tractor Lights (Platform Tractor) .....	3-86
3.16 Tractor Lights (Cabin Tractor) .....	3-87
3.17 Tilt and Telescopic Steering .....	3-88
3.18 Block Heater (Optional) .....	3-88
3.19 Driver's Seat .....	3-89
4 Operation .....	4-90
4.1 Operator Presence Control (OPC) .....	4-90
4.2 Boarding The Tractor .....	4-90
4.3 Leaving The Tractor .....	4-90

## TABLE OF CONTENTS

---

4.4 Opening The Bonnet .....	4-91
4.5 Engine .....	4-91
4.6 Turbo Engine .....	4-91
4.7 Cold Weather Starting, Temperature Below 0° C (32° F).....	4-92
4.8 Running in .....	4-92
4.9 Marching the Tractor.....	4-92
4.10 Acceleration Control .....	4-93
4.11 Stopping the Tractor .....	4-94
4.12 Turning off the Engine .....	4-94
4.13 Exhaust ATS .....	4-94
4.14 Clutch Pedal .....	4-94
4.15 Gear Change Levers .....	4-95
4.16 Gear Speed Lever.....	4-95
4.17 Range selector lever .....	4-95
4.18 Forward/Reverse Lever .....	4-96
4.19 PTO Lever .....	4-96
4.20 Power Take-Off .....	4-97
4.21 PTO Speed Selection (A) .....	4-98
4.22 Independent PTO Lever ( <b>B</b> ) .....	4-99
4.23 Service Brake (A) .....	4-101
4.24 Parking Brake (C) .....	4-101
4.25 Dual Air Trailer Brake (Optional feature) .....	4-102
4.26 Hydraulic Trailer Brake (HTB) (Optional feature) .....	4-103
4.27 Differential Lock .....	4-104
4.28 Ground Speeds .....	4-104
4.29 Adjusting Rear Wheel Track.....	4-105
4.30 Wheels and Tyres .....	4-106
4.31 Ballasting the Front Axle .....	4-107
4.32 Adjusting The Maximum Steering Angle for 4WD Axle.....	4-107
4.33 Ballasting with water for Rear wheels.....	4-108

## TABLE OF CONTENTS

---

4.34 Hitching Implements .....	4-109
4.35 Unhitching Implements .....	4-110
4.36 Quick Attach Three Point Linkage and Ladder Hitch with Clevis (Optional Feature) .....	4-110
4.37 Quick-Coupling (Hook-Type) Draft Links .....	4-111
4.38 Three-point Linkage .....	4-114
4.39 Hydraulic Controls Operations .....	4-115
4.40 Top Link Attachment to Rocker Base .....	4-116
4.41 Auxiliary Circuit (2DA/3DA).....	4-116
4.42 Safety Structure (ROPS) .....	4-117
4.43 Hydraulic Valve Adjustment .....	4-118
4.44 Auto Lift .....	4-119
4.45 Four Wheel Drive (4WD) Operation .....	4-119
4.46 Tractor Transport.....	4-120
4.47 Front Loader Mounting Points.....	4-121
4.48 Jack Up the Tractor - Lifting Points .....	4-122
5 Maintenance.....	5-123
5.1 Routine Maintenance Table.....	5-123
5.2 Fuel Tank Filling.....	5-127
5.3 Maintenance of Air Cleaner (Dry) .....	5-128
5.4 Engine Oil Level .....	5-129
5.5 Replacement of Engine Oil & Engine Oil Filter .....	5-129
5.6 Replacement of Spin-on Fuel Filter.....	5-131
5.7 Radiator.....	5-132
5.8 Power Steering Reservoir Oil Level .....	5-134
5.9 Transmission / Hydraulic Oil Filter .....	5-134
5.10 Clutch Pedal .....	5-135
5.11 Foot Brake Pedals .....	5-135
5.12 Oil Changes in 4WD Front Axle (optional feature).....	5-136

# TABLE OF CONTENTS

---

5.13 Oil Changes for Transmission, Rear Final Drives and Power Lift	
Hydraulic Circuits .....	5-137
5.14 Cleaning of Suction Strainer .....	5-138
5.15 Inspection of Hoses .....	5-139
5.16 General Maintenance of Electrical System .....	5-139
5.17 Battery and its Maintenance .....	5-140
5.18 Starter Motor .....	5-141
5.19 Alternator .....	5-141
5.20 Long Idle Period .....	5-142
5.21 Greasing Points.....	5-143
5.22 Oil and Lubrication Chart .....	5-144
6 Technical Specifications .....	6-145
6.1 Technical Specifications: .....	6-145
6.2 Matching Implements .....	6-146
7 Do's & Dont's.....	7-147
7.1 DO'S & DONT'S.....	7-147
7.2 DO'S & DONT'S.....	7-150
8 Trouble Shooting .....	8-151
8.1 Trouble Shooting .....	8-151
8.2 Trouble Shooting .....	8-153
8.3 Trouble Shooting .....	8-154
Service Record .....	8-155

# 1. INTRODUCTION & TRACTOR IDENTIFICATION

---

## 1.1 Using this Operator Manual

This manual is an important part of your tractor and it should be kept with the tractor even when you sell it.

Reading this manual will help you and others avoid personal injury or damage to the tractor. Information provided in this manual will help you to use the tractor in safest and effective way.

If you have an attachment, use the safety and operating information in the attachment operator's manual along with the tractor operator's manual to operate the attachment safely and correctly.

This manual and safety signs on your tractor may also be available in other languages (contact your dealer for more information).

The tractor shown in this manual may differ slightly from your tractor, but will be similar enough to help you understand our instructions.

Throughout this manual, the use of terms Left Side, Right Side, Front Side and Rear Side must be understood, to avoid any confusion when following these instructions. The Left and Right means left and right sides of the Tractor when facing in the direction of forward travel, reference to the Front indicates the radiator end of the Tractor, while the Rear, indicates the draw bar end.

Always specify the tractor Chassis and Engine serial numbers when ordering spare parts. This will facilitate correct & faster delivery of required parts. For easy reference, we suggest you to record these numbers in the space provided in the 'Ownership and Tractor details' page before this Chapter.

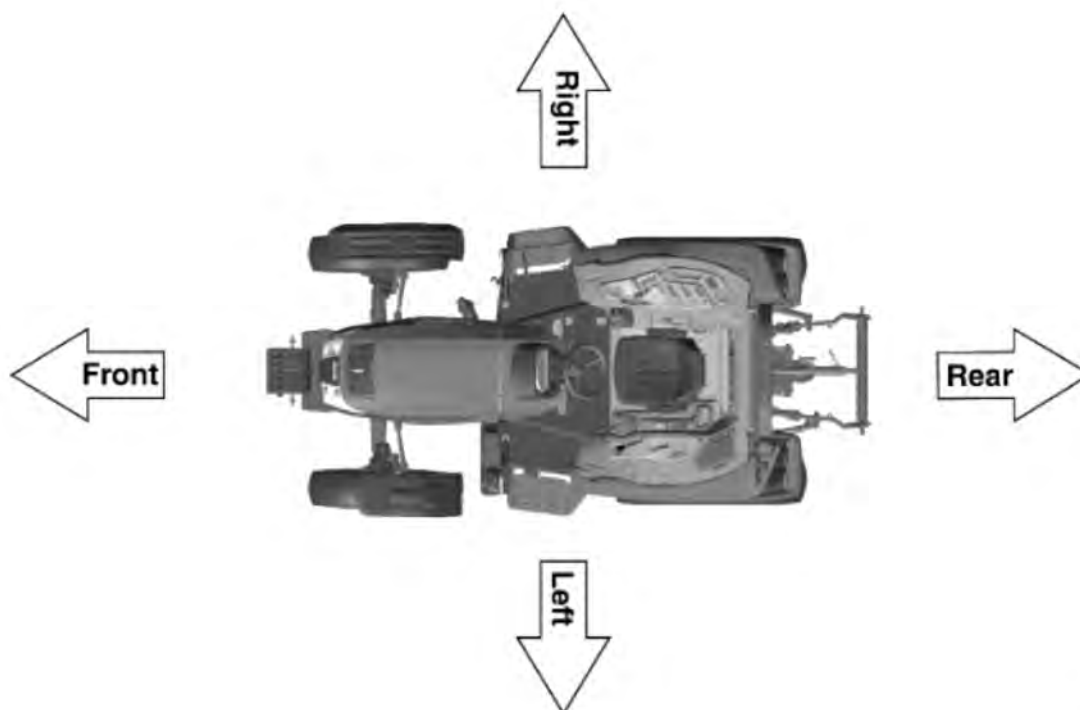

ITL000252

# 1. INTRODUCTION & TRACTOR IDENTIFICATION

## Tractor Identification — Platform

### 1.2 Chassis Serial Number (A) Platform

Chassis and/or engine serial numbers are used to register the vehicles. They are also used to assist your dealer when ordering or referring to special service information. Whenever you have occasion to consult your dealer, remember to identify your vehicle with this number. The chassis number is punched on right side of front axle bracket of the tractor. If you find the difficulty to read the number, you will find it on the statutory plate.

### 1.3 Engine Serial Number (B) Platform

Engine serial number is engraved on the cylinder block of the Engine, as shown in figure.

### 1.4 Statutory Plate (C) Platform

Chassis number is also engraved on Statutory /Data plate, which is located on left hand side fender.

### 1.5 ROPS Certificate Plate (D) Platform

ROPS certificate plate is riveted on ROPS as shown in figure. Information about ROPS serial number and tractor model is engraved on ROPS plate.

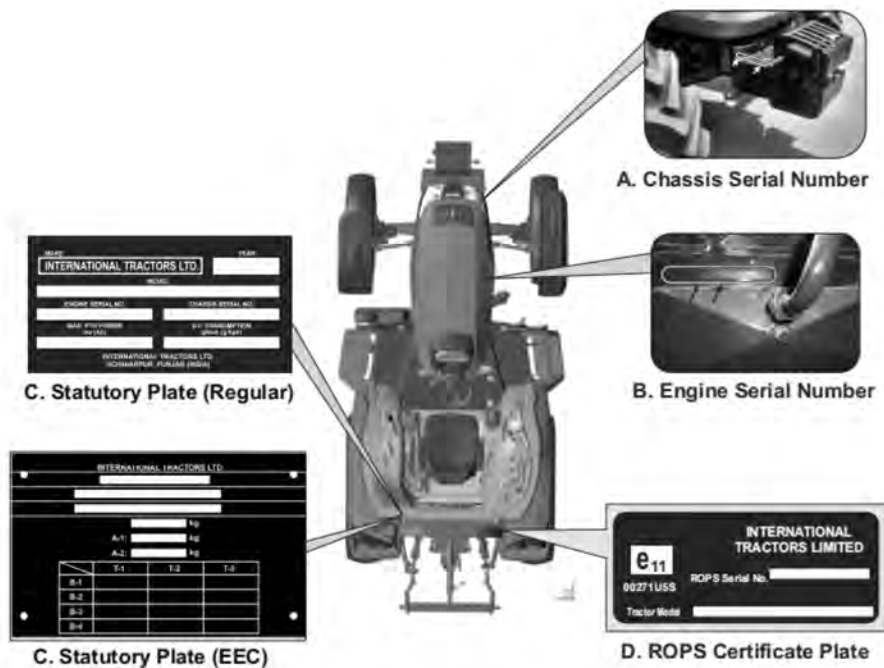

ITL000253



# 1. INTRODUCTION & TRACTOR IDENTIFICATION

## Tractor Identification — Cabin

### 1.2 Chassis Serial Number (A) Cabin

Chassis and/or engine serial numbers are used to register the vehicles. They are also used to assist your dealer when ordering or referring to special service information. Whenever you have occasion to consult your dealer, remember to identify your vehicle with this number. The chassis number is punched on right side of front axle bracket of the tractor. If you find the difficulty to read the number, you will find it on the Statutory plate.

### 1.3 Engine Serial Number (B) Cabin

Engine serial number is engraved on the cylinder block of the Engine, as shown in figure.

### 1.4 Statutory Plate (C) Cabin

Chassis number is also engraved on Statutory /Data plate, which is located on left hand side fender.

### 1.5 Cabin Plate (D)

ROPS certificate plate is riveted on ROPS as shown in figure. Information about ROPS serial number and tractor model is engraved on ROPS plate.

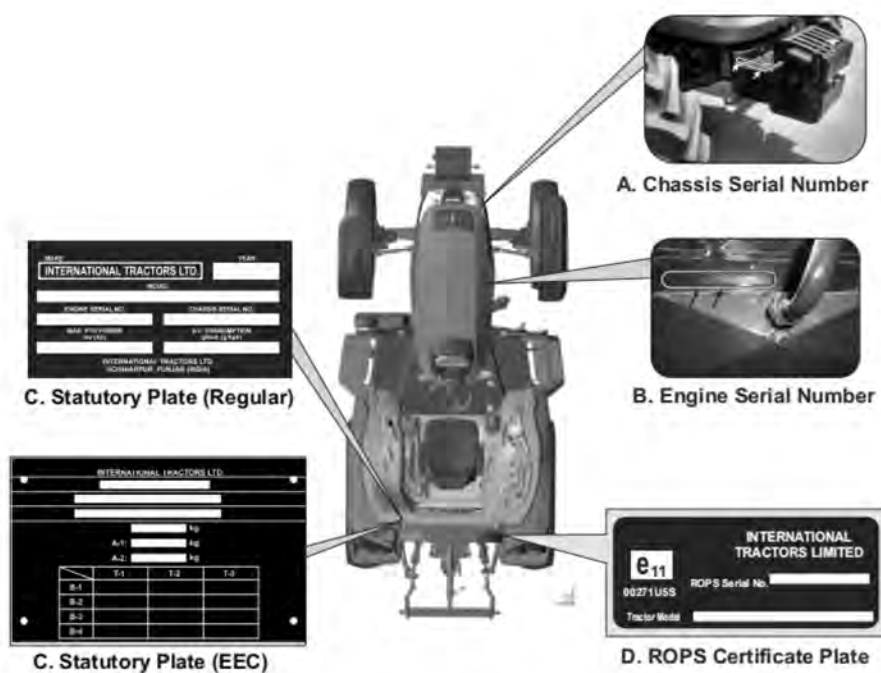

























ITL000253

# 1. INTRODUCTION & TRACTOR IDENTIFICATION

## 1.6 Universal Symbols

As a guide to the operation of your tractor, various universal symbols have been utilized on the instruments, controls and other places on tractor. The symbols are shown below with an indication of their meaning.

	Read Operator's Manual		Audible Warning Device
	Safety Alert Symbol		Four-Wheel Drive-On
	Fuel Level		Four-Wheel Drive-Off
	Engine Rotational Speed		Fast
	Parking Brake		Slow
	Air Cleaner Clogging Sensor		Engine Coolant-Temperature
	Battery Charging Condition		PTO 540
	Engine Oil-Pressure		PTO 540 Economy
	Turn Signal		Differential Lock
	Power Take-Off Clutch Control-Off Position		Hydraulic Control-Lowered Position
	Power Take-Off Clutch Control-On Position		Hydraulic Control-Raised Position
	Hazard Warning Lights		Engine Speed Control
	Master Lighting Switch		Remote Cylinder-Retract
	Parking Brake Indication		Remote Cylinder-Extend
	Headlight-Low Beam		Engine Stop
	Headlight-High Beam		

## 2. WARRANTY & SAFETY NOTES

### 2.1 Introduction

**NOTE :** WARRANTY WILL BE REIMBURSED AS PER THE WARRANTY POLICY, KINDLY CONTACT NEARBY DEALER/DISTRIBUTOR.



E-marked indicated component are applicable for countries under European Economic Community (EEC) Compliance.

**NOTE :** This book is published for worldwide distribution, and availability of equipment shown either as basic or accessory may vary according to the territory in which the tractor is to be operated. Full details of equipment available in your area can be obtained from your Dealer

The purpose of this book is to enable the owner and driver to operate the tractor in a safe manner. Providing that the instructions are followed carefully, the tractor will give years of service in our tradition

The installation of the product by the Dealer gives the opportunity to ensure that the operating and maintenance instructions are understood. Always consult your Dealer if do not understand any part of this book. It is important that these instructions are understood and observed. Daily maintenance should become a routine, and a record of hours in service should be kept.

When new parts are required it is important that only genuine service parts are used. Our Authorized Dealers supply genuine parts and can give advice regarding their fitment and use. Extensive damage may occur as a result of the fitment of parts of inferior quality, Customers are advised to buy their service parts only from an authorized Dealer

Owing to wide variations in operating conditions, it is impossible for the Company to make comprehensive or definitive statements in its publications regarding performance or methods of use of its machines, or to accept liability for any loss or damage which may result from these statements, or from any errors or omissions. If the tractor is to be used for abnormal conditions which may be detrimental (e.g. deep water or paddy fields) consult your Dealer for special instructions, or the warranty may be invalidated.

These tractors are designed solely for use in customary agricultural operations (intended use).

Use in any other way is considered as contrary to the intended use. The tractor manufacturer accepts no liability for any damage or injury resulting from misuse and these risks must be borne solely by the user. Compliance with, and strict adherence to, the conditions of operation, service and repair as specified by the manufacturer also constitute essential elements for the intended use.

These tractors should be operated, serviced and repaired only by persons familiar with all their particular characteristics and who are acquainted with the relevant safety rules (accident prevention).

Customers are strongly advised to use an official authorized Dealer in connection with any service problems and adjustment that may occur.

## 2. WARRANTY & SAFETY NOTES

### 2.2 Warranty, Pre—delivery and Installation

The Company, when selling new goods to their Dealers, gives a warranty which, subject to certain conditions, guarantees that the goods are free from defects in material and workmanship. Since this book is published for worldwide circulation, it is impossible to detail the exact terms and conditions of warranty that apply to a retail customer in any particular country. Purchasers of new equipment should request full details from their supplying Dealer.

In accordance with the Company policy of continuous improvement to its machines, alterations in the specifications of machines may be made at any time without notice. The Company accepts no responsibility for discrepancies which may occur between the specifications of its machines and the descriptions thereof contained in its publications.

A dealer is required to carry out certain activities when supplying a new tractor. These consist of a full pre-delivery inspection to ensure that the tractor supplied is ready for immediate use, and full instruction in the basic principles of operation and maintenance of the tractor. These instructions will cover instruments and controls, routine maintenance and safety precautions.

All persons who will be concerned with the operation and maintenance of the machine should be present for these instructions.

**NOTE:** The tractor manufacturer will not accept responsibility for any claim resulting from the fitment of non-approved parts or attachments, or unauthorized modification or alteration.

### 2.3 Warranty Procedure

Correct installation, coupled with regular maintenance, will do much to prevent breakdowns. If, however, operating trouble is experienced during the warranty period, the following procedure must be adopted:-

Immediately notify the Dealer from whom you purchased the tractor, quoting the Model and Serial Number. It is most important that there should be no delay, and you should realize that, even where the original failure is covered by warranty .if the failure is not repaired immediately, warranty cover may not apply.

Provide your Dealer with as much background information as you can. It will help him to know how many hours service has been achieved, the type of work on which you are engaged and the symptoms of the trouble.

It should be noted that normal maintenance services such as tuning, brake/clutch adjustments, and the supply of materials used to service the tractor (oil, filters, fuel and antifreeze) are not covered by terms of the warranty.

### 2.4 Parts Warning

The fitment of non genuine parts may result in a part of substandard quality being used. The tractor manufacturer will not take the responsibility for any loss, damage or liability resulting from the fitment of such parts.

if fitted during the normal warranty period the manufacturer's guarantee may be invalidated.

## 2. WARRANTY & SAFETY NOTES

---

### 2.5 If You Move

Only the official dealer from whom you purchase the tractor is responsible for the protection afforded by your warranty and, where possible, you should always take the tractor to him for repair. If, however, you move to another area or if your tractor should be working temporarily at some distance from the Dealer from whom it was purchased, you are recommended to obtain from the original Dealer the name and address of the Dealer nearest to your new location and to ask for arrangements to be made for outstanding service warranty commitments to be transferred to the latter.

If you have left the area in which the original Dealer operates and have not made arrangements with your new Dealer, the latter will readily provide assistance in emergency but you will be charged at normal rates for any work undertaken unless:

- You make it clear that the warranty has not expired.
- You give the repairing Dealer the opportunity to make suitable arrangements with the retailing Dealer.

### 2.6 Service After Warranty

During the warranty period, you should have all your repairs and maintenance performed by your dealer. This ensures that a detailed check is kept on the progress and performance of your new tractor.

In order to obtain the best results from your tractor it is important that regular maintenance and service checks continue after the warranty period has expired. Make use of your local Dealer for all major tractor services; a trained engineer will spot any problems between the service and the next.

The mechanics are regularly trained and updated on the product, servicing techniques and the use of modern service tools and diagnostic equipment. They receive regular Service Bulletins; have all Workshop Manuals and other such technical information to ensure that the repair or service is to the standard required.

### 2.7 Safety

The safety of operator is one of the main concerns in designing and developing a new tractor. Designers build in as many safety features as possible. However, every year many accidents occur which could have been avoided by a few seconds thought and a more careful approach to handling farm machinery and implements.

Read and implement the safety instructions detailed in the next section of this book.

**WARNING** :In some of the illustrations used in this Operator instruction Book, panels or guards may have been removed for clarity. Never operate the tractor without these components in position. If the removal of panels or guards is necessary to make a repair, they **MUST** be replaced before operation

## 2. WARRANTY & SAFETY NOTES

---

### 2.8 Safety Alert Symbols and Terms



The safety alert symbol identifies important safety messages on machines, safety signs, in manuals or elsewhere. When you see this symbol, be alert to the possibility of personal injury or death.

**Why is SAFETY important to you? \*ACCIDENT DISABLE and KILL\***

**ACCIDENTS are COSTLY \*\* ACCIDENTS can be AVOIDED\***

#### **SAFETY: TRACTOR and IMPLEMENT**

- The tractor is a source of power: Both mechanical and hydraulic.
- On its own, the tractor is of little practical value. Only when used in conjunction with an implement or other attachment does it become a working unit.
- This instruction book is compiled to cover those safe working practices that are associated with the base tractor operation.
- It does not cover all operation and safety instructions relevant to all known implements and attachments that may be fitted at the time of tractor delivery or at some future date.
- It is essential that operators use and understand the relevant instruction manual of such implements and attachments.

### 2.9 Safety: Introduction

This safety section of your Operator Instruction book is intended to point out some of the basic safety situations which may be encountered during the normal operation and maintenance and to suggest possible ways of dealing with these situations. This section is NOT a replacement for other safety practices featured in other sections of this book.

Additional precautions may be necessary depending on attachments used and conditions at the work site or in the service area. The tractor manufacturer has no direct control over tractor application, operation, inspection, lubrication or maintenance. Therefore it is YOUR responsibility to use good safety practices in these areas.

## 2. WARRANTY & SAFETY NOTES

### 2.10 Safety: A word to the Operator

It is YOUR responsibility to read and understand the safety section in this manual before operating your tractor. You must follow these safety instructions that take you step by step through your working day.

In reading this section, you will note that illustration shave been used to highlight certain situations. Each illustration is numbered and the same number appears in the text in parenthesis. This number is placed at the end of the written text that refers to the illustration and is made up of two digits, separated by a dot: the first digit designates the chapter, the second one of the figure number in that chapter (e.g. Fig.2.34 of chapter 2).

Remember that YOU are the key to safety. Good safety practices not only protect you, but also the people around you. Study the features in this manual and make them a working part of your safety program.

Keep in mind that this safety section is written only for this type of machine. Practice all other usual and customary safe working precautions, and above all.

**REMEMBER: SAFETY IS YOUR RESPONSIBILITY. YOU CAN PREVENT SERIOUS INJURY.**

### 2.11 Safety: Danger, Warning and Caution

Whenever you see the words and symbols shown below, used in this book and on decals, you MUST take note of their instructions as they relate to personal safety.



**DANGER** : The symbol and the word DANGER indicates an imminently hazardous situation, which, if not avoided, will result in DEATH OR VERY SERIOUS INJURY.



**WARNING** : The symbol and the word WARNING indicate a potentially hazardous situation. if the instructions or "procedures are not correctly followed it could result in DEATH OR SERIOUS INJURY.



**CAUTION:** The symbol and the word CAUTION indicate a "potentially hazardous situation, which, if not avoided, may result in MINOR INJURY.

**IMPORTANT:** The word IMPORTANT is used to identify special instructions or procedures which, if not strictly observed, could result in damage to, or destruction of the machine, process or its surroundings.

**Note :** The word NOTE is used to indicate point of particular interest for more efficient and convenient repair or operation

## 2. WARRANTY & SAFETY NOTES

### 2.12 Safety: Decals

**WARNING: DO NOT remove or obscure Danger, Warning, Caution or Instruction decals.**

Replace any Danger, Warning, Caution or Instruction Decals that are not readable or are missing. Replacement decals are available from your Dealer in the event of loss or damage. The actual location of these safety Decals is illustration at the end of this section.

If a used tractor has been purchased, refer to the illustration at the end of this section to ensure that all the safety warning decals are in the correct position and are readable.

### 2.13 Safety: Follow A Safety Program

#### **For safe operation:**

For safe operation of an agricultural tractor, you must be a qualified and authorized operator. To be qualified you must understand the written instructions supplied in this Operator Instruction Book, have training, and know the safety rules and regulations for the job.

Some regulations specify, for example, that no one under the age of 18 years (according to European Rules) may operate power machinery.

This includes tractor, it is your responsibility to know what these regulations are, and obey them, in the operating area of situation.

These will include, but are not limited to, the following instructions for safe tractor operations:

**Warning : An operator should not use alcohol or drugs which can change his/her alertness or coordination. An operator on prescription or 'over the counter' drugs needs medical advice on whether or not he or she can properly operate machines.**

#### **Observe the following precautions:**

- NEVER allow children or unqualified persons to operate your tractor. Keep others away from your area of work.
- Securely fasten your seat belt.
- Where possible, avoid operating the tractor near ditches, embankments and holes. Reduce speed when turning, crossing slopes, and on rough, slippery, or muddy surfaces.
- Stay off slopes too steep for safe operation.
- Watch where you are going, especially at row ends, on roads, and around trees.
- DO NOT permit others to ride on the tractor or the implement unless an approved passenger seat is fitted.
- Hitch only to the draw bar and recommended hitch points, and never above the center line of the rear axle.
- Operate the tractor smoothly - no jerky turns, starts or stops, when the tractor is stopped, apply the parking brakes securely.
- Never modify or remove any part of the equipment and never use attachments unless they are properly matched to your tractor.



## 2. WARRANTY & SAFETY NOTES

### 2.14 Safety Frame

A Safety frame (A) and seat belt is fitted as standard equipment to the platform tractor at the time of factory assembly. If the safety frame was deleted by the original purchaser or has been removed, it is recommended that you equip your tractor with a Safety frame and a seat belt. Safety frames are effective in reducing injuries during overturn accidents See fig.2.14



**WARNING :** A tractor overturning without safety frame can result in serious injury or death.



Fig 2.14

ITL000001

#### Operation:

- Before using the tractor ensure that the safety frame is not damaged, that it is securely fastened to the tractor.
- If the safety frame has been removed from the tractor, it must be refitted or erected immediately using the proper hardware and applying the recommended torque value.
- DO NOT ATTACH chains, ropes or cables to the safety frame for pulling purposes; this will cause the tractor to tip backwards. Always pull from the tractor drawbar.
- Always wear your seat belt-adjusted snugly except when operating with folded down safety frame or if the safety frame has been removed.
- Check the seat belt for damage. A damaged seat belt must be replaced.

#### Damage to the safety frame

If the tractor has rolled over or the safety frame has been damaged (such as striking an overhead object during transport), the safety frame must be replaced to provide the original degree of protection

After an accident, check for damage to the safety frame, operator's seat, seat belt and seat mountings. Before you operate the tractor, replace all damaged parts.

**IMPORTANT: DO NOT WELD, DRILL, BEND OR STRAIGHTEN THE SAFETY FRAME.**

## 2. WARRANTY & SAFETY NOTES

### 2.15 Safety: Prepare For Safe Operation

#### Protect yourself:

Wear all the protective clothing and personal safety devices issued to you or called for by job conditions. Don't take risk hence you may carry/wear the following:

- (a) A hard hat
- (b) Safety glasses, goggles or face shield
- (c) Hearing protection
- (d) Respirator or filter mask
- (e) Inclement weather clothing
- (f) Reflective clothing
- (g) Heavy gloves (neoprene for chemical, leather for rough work).
- (h) Safety shoes

DO NOT wear loose clothing, jewellery or other items and tie up long hair which could catch on controls or other parts of the tractor.

Learn where fire extinguishers and first aid or emergency equipment is kept and where to get help in a hurry. Make sure you know how to use this equipment.



Fig 2.15

ITL000002

## 2. WARRANTY & SAFETY NOTES

### 2.16 Know Your Equipment:

Know your tractor. Know how to operate all equipments on your tractor and the implements attachments used with it. Know the purpose of all the controls, gauges and dials. Know the rated load capacity, speed range, braking and steering characteristics, turning radius and operating clearances.

Keep in mind that rain, snow, ie, loose gravel, soft ground, etc. can change the way your tractor operates.

**Under poor conditions, slow down and be extra careful, engage four wheel drive (4x4).**

Study the DANGER, WARNING or CAUTION safety signs on your tractor and the information signs also. Read this operator instruction book before starting the engine. Study it before you start the work (fig 2.16).

If there is something in the manual you don't understand, ask someone (such as your dealer) to explain it to you.

**IMPORTANT : This manual covers general safe practices for agricultural tractor it must always be kept with the tractor. For further copies contact your Dealer.**

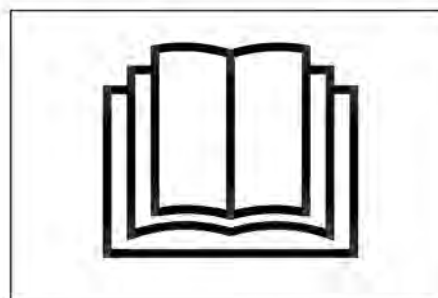

Fig 2.16

ITL000003



Strictly follow the instructions outlined in the operator's manual of the mounted or trailed machinery or trailer, and not to operate the combination tractor — machine or tractor — trailer unless all instructions have been followed.

## 2. WARRANTY & SAFETY NOTES

### 2.17 Use all Available Protective Devices

Keep all protective devices in place and securely fastened. Make certain all guards, shields safety signs are properly installed, as specified, and are in good condition.

**IMPORTANT: To help keep you and others around you safe, your tractor should be equipped with:**

- Safety belt
- Tractors PTO shield (Fig. 2.17a).
- Rear view mirrors (Fig. 2.17a).
- Fire extinguisher (Fig. 2.17b).
- SMV (Slow Moving Vehicle) emblem, Additional guards, lights or decals and additional alarm (Fig. 2.17c).
- Safety frame
- Know which devices are required for safe operation of your tractor. Use them. Make sure they are in place and in good condition. NEVER remove or disconnect any safety device.

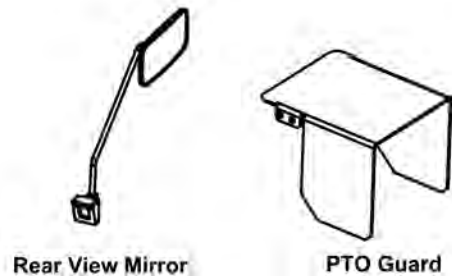

Fig 2.17 (a)

ITL000005



Fire Extinguisher

Fig 2.17 (b)

ITL000006

### 2.18 Check the Tractor

- Before you begin your working day, take time to check your tractor and ensure that all systems are in good operational condition.
- DO NOT smoke while refueling the tractor. Keep any type of open flame away.
- Check for loose, broken, missing, or damaged parts. Have everything put into good repair. Make certain all safety devices are in place.
- Check safety frame and seat belt for damage. A damage safety frame or seat belt MUST be replaced.
- Ensure that implements and attachments are properly installed and that the tractor and implement PTO RPM ratings match.



Fig 2.17 (c)

ITL000007

## 2. WARRANTY & SAFETY NOTES

- Check the tyres for cuts, bulges and correct pressure. Replace worn or damaged tyres. Check foot and parking brakes for proper operation. Adjust, if necessary.
- Stop the engine, wait for it to cool before refueling and checking the engine oil level.
- Perform all maintenance procedures outlined in the maintenance section of this manual.
- Check that the tractor PTO shield and drive line guards are in place and operating properly.
- Check the tractor hydraulic and implement hydraulic system. If any leakage or damaged parts observed, repair or replace the same.



Fig 2.18

ITL000008

**WARNING:** Diesel fuel or hydraulic fluid under pressure can penetrate the skin or eyes and cause serious personal injury, blindness or death. Fluid leaks, under pressure, may not be visible. Use a piece of cardboard or wood to find leaks. Never use your bare hand. Wear safety goggles for eye protection. If any fluid is injected into the skin, it **MUST** be surgically removed within a few hours by a doctor familiar with this type of injury, fig. 2.18

Before applying pressure to the fuel or hydraulic system, be sure all connections are tight and that lines, pipes, and hoses are not damaged. Before disconnecting fuel or hydraulic lines, be sure to relieve all pressure.

Make sure that all hydraulic lines are correctly installed and are not tangled.

**WARNING :** Liquid cooling systems build up pressure as the engine gets hot. Before removing the radiator cap, stop the engine and let the system cool.

Check the engine cooling system and add coolant as required.

### 2.19 Clean the tractor

- Keep work surfaces and engine compartments clean.
- Before cleaning the machine, always lower implements to the ground, place transmission in neutral, engage the parking brake, shut off the engine and remove the key.
- Clean steps, pedals and floor. Remove grease or oil, Brush away dust or mud. In winter, scrape away snow and ice. Remember-slippery surfaces are dangerous.
- When plastic parts need to be cleaned (such as console, instrument panel, monitors, indicators etc.), do not use petrol, paraffin, diluents etc.
- They could cause discoloration, cracking or warping of the cleaned parts.
- These parts should **ONLY** be cleaned with water, neutral soap and a soft cloth.
- Remove and store implements, keys, hitches etc. in their proper places.

## 2. WARRANTY & SAFETY NOTES

### 2.20 Protect the environment

It is illegal to pollute drains, water courses or soil. Use authorized waste disposal facilities, including civic amenity sites and garages providing facilities for disposal of used oil. If in doubt, contact your local authority for advice.

To get to know the correct methods to dispose of oils, filters, tyres etc. contact your Dealer or the local agency for waste recycling.

### 2.21 Safety: Servicing The Tractor

DO NOT service the tractor while the engine is running or hot, or if the tractor is in motion (Fig. 2.21).

Before making adjustments to, or servicing the electrical system, disconnect the battery cables, negative (-) cable first.

To prevent fires or explosions keep open flames away from the battery to cold weather starting aids. To prevent sparks which could cause explosion use jumper cables according to instructions.

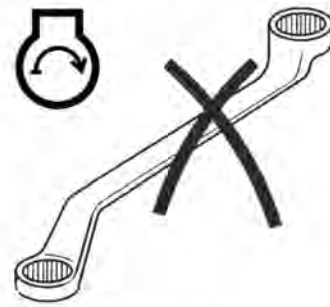

Fig 2.21

ITL000009

When making repairs or adjustments it is recommended that you consult your Dealer, and have the work carried out by trained personnel.

The implement and/or tractor must be supported on suitable wooden blocks or stands, NOT a hydraulic jack.

Check all nuts and bolts periodically for tightness especially wheel hub and rim nuts. Tighten to the prescribed torque values.

Check the power steering reservoir regularly and top up as necessary with approved oil.

Check the brakes regularly, top up the reservoir and/or adjust where necessary. Make sure that the brakes are evenly adjusted.

## 2. WARRANTY & SAFETY NOTES

### 2.22 Safety: Starting

#### Warn bystanders before starting:

Before starting, Walk all around the tractor and any attached equipment. Make sure that no one is under it, on it, or close to it. Let other workers and bystanders know you are starting up and don't start until everyone is clear of the tractor, implements and towed equipment.

Ensure that all bystanders, particularly children are in a safe position before starting the engine.

#### Mount and dismount properly:

Always use 'three point contact' with the machine, and face the machine when you mount it. Three point contact means both hands and one foot or one hand and both feet are in contact with the machine at all times during mounting and dismounting.

Clean the soles of your shoes and wipe your hands before climbing on. Use handrails, grip handrails, ladders or steps (as provided) when mounting or dismounting.

NEVER use control levers as a hand hold and NEVER step on foot controls when mounting or dismounting.

#### Start Safely:-

**WARNING** : Before starting the engine, make sure there is plenty of ventilation (fig.2.22a). Never operate the engine in a closed building. The exhaust fumes may cause asphyxiation (fig.2.22b).

Always start the engine from the operator's seat with all the transmission levers and PTO lever in neutral.

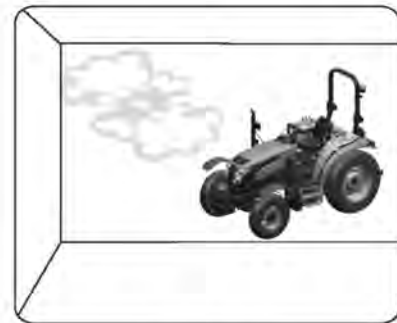

Fig 2.22 (a)

ITL000010



Fig 2.22 (b)

ITL000011



Fig 2.22 (c)

ITL000012

## 2. WARRANTY & SAFETY NOTES

Make sure that the tractor dual brake pedals are locked together at all times unless you are making turns in the field which require independent use of the brakes. Make sure the brakes are properly adjusted so that both brakes engage at the same time.

Adjust the seat, fasten the seat belt (where applicable as outlined in this manual), apply the parking brake and put all controls in neutral before starting up.

**DANGER** : Start the engine, with the starter key, from the operator's seat only. Never attempt to start the engine by shorting across the starter terminals. The machine will start in gear if the neutral start circuit bypassed. This could cause serious injury or death to anyone near the tractor (fig. 2.22 c).

### 2.23 Follow recommended starting procedures

Follow the starting procedures recommended in the "Operation" section of this Operator Manual. This includes normal starting, cold starting and use of starting fluids.

#### Test the controls

After starting, recheck all gauges and lights. Make sure everything is functioning correctly. If the tractor does not respond correctly which each control is operated, DO NOT use the tractor until the fault is rectified.

Ensure that the starter solenoid cover is always in position.

#### Starting fluid

**WARNING** : It is very important that you read the label on the can before using starting fluid. DO NOT use aerosol can of starting aid on tractors with the thermostat connected to the electrical system. Ether combined with thermostat can cause an explosion with damage to engine, personal injury or both.



Fig 2.23 (a)

ITL000013

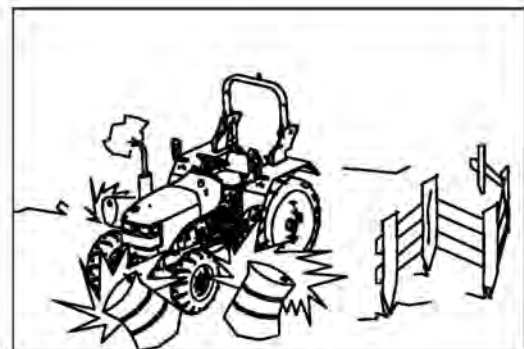

Fig 2.23 (b)

ITL000014



## 2. WARRANTY & SAFETY NOTES

Handle starting fluid correctly (fig.2.23a). Starting fluid must only be used when an ether start aid is fitted as original equipment by the manufacturer or when installed by a Dealer as an accessory, in case of tractors being fitted with glow plugs or thermostat, this must be removed prior to the installation.

If aerosol cans of starting fluid are to be used the thermostat must be disconnected. Remove the wire from the thermostat unit which will be found on the induction manifold. Tape the end of wire to prevent an electrical short circuit.

Before starting the tractor, ensure that no persons or hindrances are present in its range (fig.2.23b).

### 2.24 Safety: Work Safety



**WARNING :** An unbalanced tractor could overturn and cause injury or death. Make sure safety frames counterweights, wheel weights and wheel ballast are used as recommended by the manufacturer. NEVER add extra counter weights to compensate for an overload.

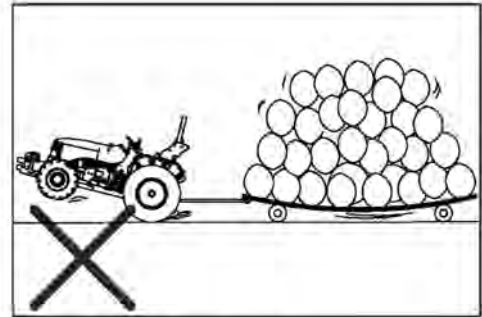

Fig 2.24

ITL000015

### 2.25 Make the right moves

Make sure your tractor is ready for the job it must do. Know the rated load capacities of your tractor and never exceed them. Be certain that any equipment or implements you intend to use DO NOT exceed the load rating of your tractor. Be sure the tractor and implement PTO rev/min match.

Keep in mind that tractors normally operate on uneven, unpaved, and often bumpy or sloping surfaces. Operating conditions can reduce the amount of weight you should carry or pull.



**WARNING:** Do not start the tractor without ensuring a perfect command of speed and steering controls.

## 2. WARRANTY & SAFETY NOTES

### 2.26 Follow safe operating practices

- Operating the controls smoothly: don't jerk the steering wheel or other controls.
- DO NOT get on or off a moving tractor, keep a firm grip on the steering wheel at all times, with the thumbs clear the spokes when driving the tractor
- Make sure you have adequate clearance in all directions for tractor, safety frame and implement.
- NEVER play games with a tractor or equipment.
- Before getting off the tractor, always disengage the PTO, lower all attachments and implements to the ground, place the tractor in neutral, engage parking brake, shut off the engine and remove the key.

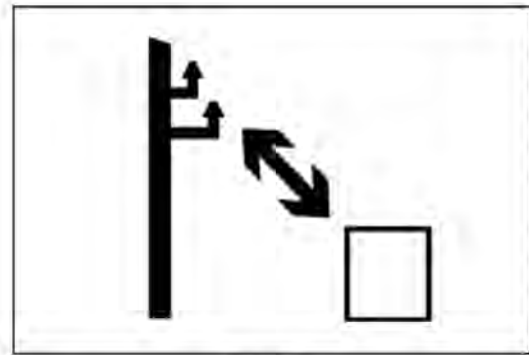

Fig 2.26

ITL000016

DO NOT touch, lean on, or reach through any implement mechanism or permit others to do so.



**WARNING:** Accidental contact with high voltage, lines cause death. In case of contact with high -voltage conductors DO NOT leave the tractor, move the tractor and/or the loader in such a way as to eliminate the contact and reach a safe distance (Fig. 2.26).

Stay alert. Should something break, come loose, or fail to operate in your equipment, stop work, shut off the engine, inspect the machine and have repairs or adjustments made before resuming operation.

### 2.27 Watch out for others

Be aware of what is going on. Never allow an untrained or unqualified person to operate your tractor. They could injure themselves or someone else.



**WARNING:** Your tractor is a one person machine. DO NOT permit others to ride on the tractor or the implement (Fig. 2.27). In some countries a passenger seat must be fitted to carry passengers. Never allow anyone to ride on the implements or other equipment including trailers, except on certain harvesting equipment, specially designed for riders during the actual harvest operation only (not during transport). Such equipment must have provision for a safe riding area. NEVER allow children on a tractor



Fig 2.27

ITL000017

## 2. WARRANTY & SAFETY NOTES



**WARNING:** Be certain you can control both speed and direction before moving. Move slowly until you are sure that everything is operating properly. After starting, recheck the steering, right and left. Be certain you have full steering and brake control. If differential is locked, DO NOT operate at high speed or turn the tractor until the differential lock is disengaged.



**WARNING :** Never lift a load over anyone

Before starting, inspect the work area to establish the best and safest procedure. Plan your work so that you drive as straight as possible forward. Beware of trenches, pits, ditches, slopes, trunks or stumps, ponds etc. Watch for any possibly dangerous condition. If you are using a front loader or foldable implements or implements with high components, watch out for obstacle in the tractor's way.

- DO NOT lift object that cannot be contained safely in the bucket, get the appropriate attachment. Never allow anyone to stand on the safety frame or fenders.
- When using a loader, avoid sudden stops, starts, turns, or change of direction. Keep loads as near to the ground as possible.
- Keep others away from articulation joints, itches, drawbar, lift arm, PTO drive, cylinders, belts, pulleys, and other moving parts. Keep all shields and guards in place.

### 2.28 Risk of overturning

For your safety, it is recommended that all platform tractors are fitted with safety frame and seat belts (Fig.2.28)

In the event of overturning with a tractor fitted with a safety frame, hold the steering wheel firmly and DO NOT attempt to leave the seat until the tractor has come to rest. (fig. 2.28).

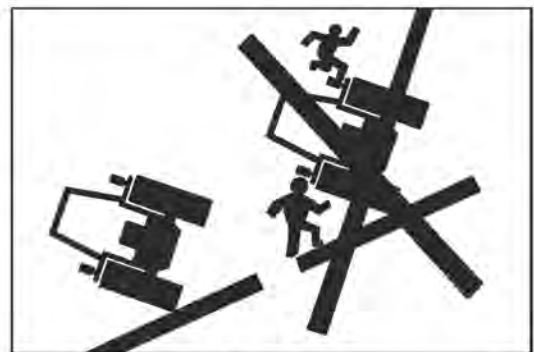

Fig 2.28

ITL000018

## 2. WARRANTY & SAFETY NOTES

### 2.29 To avoid side overturns

- Set the wheel track at the widest setting suitable for the job being done.
  - Lock the brake pedals together before driving at transport speeds.
  - Reduce speed to match operating conditions. If the tractor is equipped with a front end loader, carry the bucket and load as low as possible.
  - Make wide slow turns at reduced speed. DON'T let your tractor bounce. You may lose steering control.
  - DON'T pull a load too heavy for your tractor. It could run away on the down slope or the tractor could jackknife around a towed load.
  - DON'T brake suddenly. Apply brakes smoothly and gradually.
  - When going down a slope use the throttle to slow the tractor engine and use the same gear you would use to up the slope. Shift into gear before you start downhill.
  - Engage Four-wheel drive (4WD), this will give four-wheel braking.
- 
- It is always preferable to straight up or down a steep slope rather than across it.
  - Avoid crossing steep slopes if possible. If you must do so, avoid any holes or depressions on the downhill side (Fig.2.29a). Avoid any stumps rocks, bumps or raised areas on the uphill side. When operating near ditches or banks, always keep your tractor behind the shear line (Fig.2.29b).



**WARNING** : NEVER stand, or allow anyone else stand between the tractor and implement unless the engine is turned off parking brakes is engaged, the transmission is in neutral, and all attachments or implements are lowered to the ground.



**WARNING** : NEVER disengage the clutch or attempt to shift gear after you have started downhill.

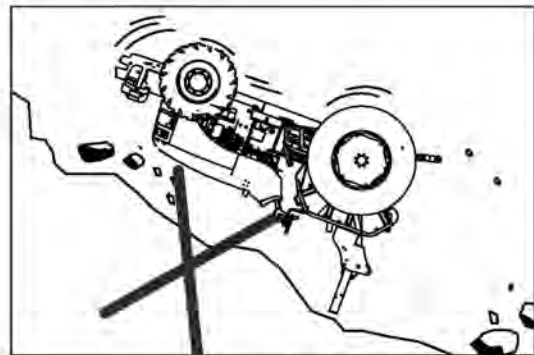

Fig 2.29 (a)

ITL000019

## 2. WARRANTY & SAFETY NOTES

If it is necessary to cross a steep slope, avoid turning uphill, slope down and make a wide turn. Travel directly up or down the slope, never across it. When traveling up or down a slope, keep the heavy end of the tractor pointed uphill (Fig.2.29c). When traveling across a slope with side mounted implements, keep the implement on the uphill side. Don't raise the implements, keep them as low to the ground as possible when crossing a slope (Fig. 2.29d).

Avoid crossing steep slopes if possible. If you must do so, avoid any holes or depressions on the downhill side. Avoid any stumps, rocks, bumps or raised areas on the uphill side (Fig. 2.29e).

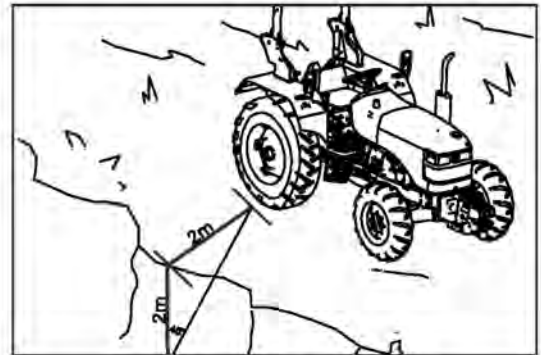

Fig 2.29 (b)

ITL000020

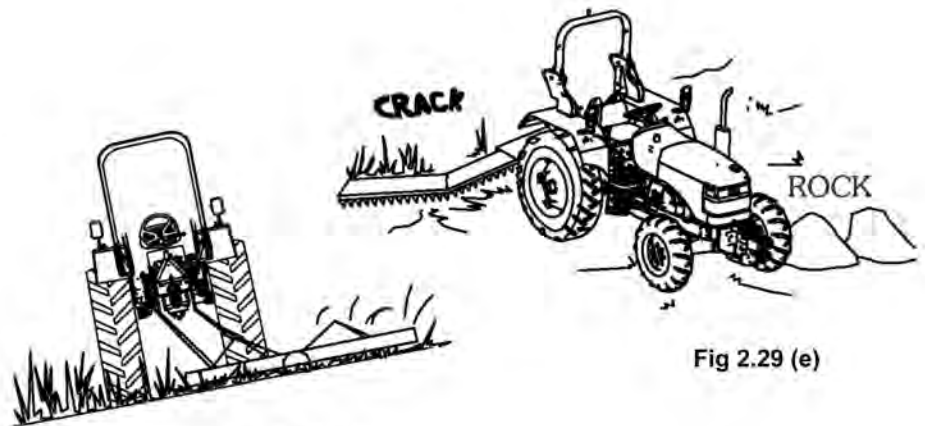

Fig 2.29 (e)

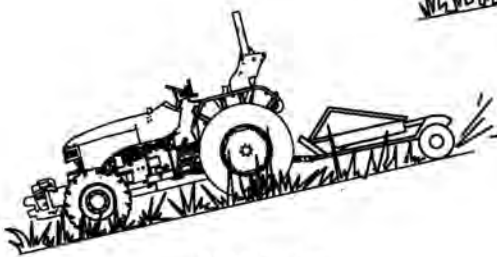

Fig 2.29 (c)

Fig 2.29 (d)

ITL000021

### 2.30 To avoid rear overturns



**WARNING** : Hitching to the rear axle, or any other point above the drawbar, can cause a rear overturn.

## 2. WARRANTY & SAFETY NOTES

DO NOT pull anything using the top link connection, or from any point above the centre line of the rear axle. Always use an approved drawbar, and only use a drawbar pin that locks into place.

High hitching can cause rear overturn, which may cause serious injury or death. Hitch loads to the drawbar only.

When using a three-point linkage drawbar, the stays must be fitted and kept in the down position.

Use front counterweights (A) to increase tractor stability when towing a heavy load or to counterbalance a heavy rear mounted implement (Fig.2.30a).

DO NOT overload your tractor and DO NOT ballast it beyond its carrying capacity. Never add ballast weight to counterbalance an overload. Reduce the load instead (Fig.2.30b).



Fig 2.30 (a)

ITL000022

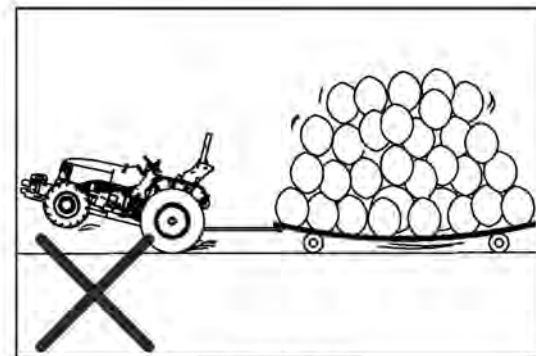

Fig 2.30 (b)

ITL000023



**WARNING** : An overload is always dangerous. Check the loading capacity of your tractor and NEVER overload.

## 2. WARRANTY & SAFETY NOTES

If the front end of the tractor starts to lift, reduce your speed (Fig. 2.30c).

If your tractor is bogged down in the mud or frozen to the ground, DO NOT attempt to drive forwards. The tractor can rotate around its rear wheels and overturn (Fig. 2.30c). Lift any attached implement and attempt to BACK OUT. If this is not possible, tow it out with another vehicle.

Start forward slowly and gradually increase your speed. If the tractor is attached to a heavy load, or immovable object, improper clutching may cause overturn (Fig. 2.30d and 2.30e).

If you get stuck in a ditch, BACK OUT, if possible. If you must go forward, do it slowly, and carefully

A bare tractor or a tractor with rear mounted attachments should be backed up the slope in reverse and travel forward downhill.

Always keep the tractor in gear when going down hill  
Never permit the tractor to coast with clutch disengaged or transmission in neutral.

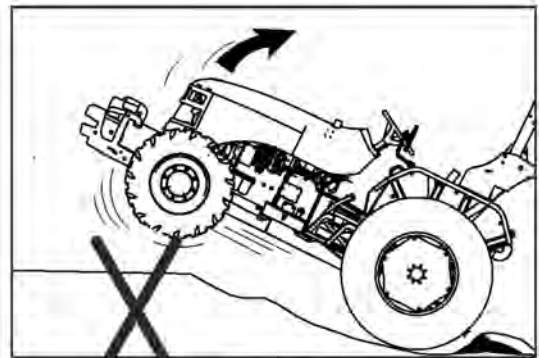

Fig 2.30 (c)

ITL000024

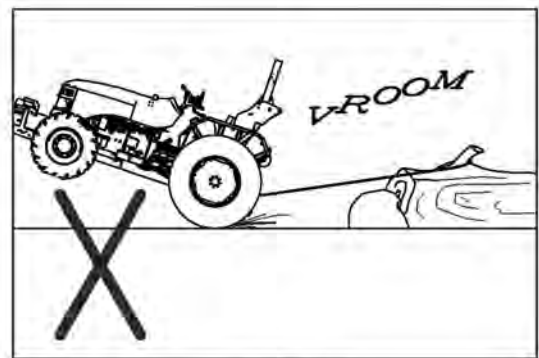

Fig 2.30 (d)

ITL000025

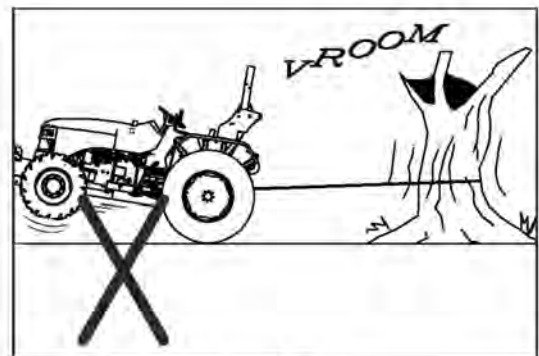

Fig 2.30 (e)

ITL000026

## 2. WARRANTY & SAFETY NOTES

### 2.31 General operating hazards

- When using chemicals, carefully follow the chemical manufacturer's instructions for use, storage and disposal. Also follow the chemical application equipment manufacturer's instructions.
- When operating under poor visibility conditions, or in the dark, use your ground speed. (DO NOT use your ploughing lights when traveling on a roadway because rear pointed white lights are illegal except when reversing and may confuse following drivers).
- Operate your tractor with the wheels set the widest setting possible, consistent with the particular task you are performing. To adjust wheel settings refer to Maintenance chapter.
- Reduce your speed when operating over rough or slippery ground when foliage restricts your view of hazards.
- DO NOT make sharp turns at high speed.
- Three point hitch and side mounted implements make a much larger arc when turning that towed equipment. Make certain to maintain sufficient clearance for safe turning.

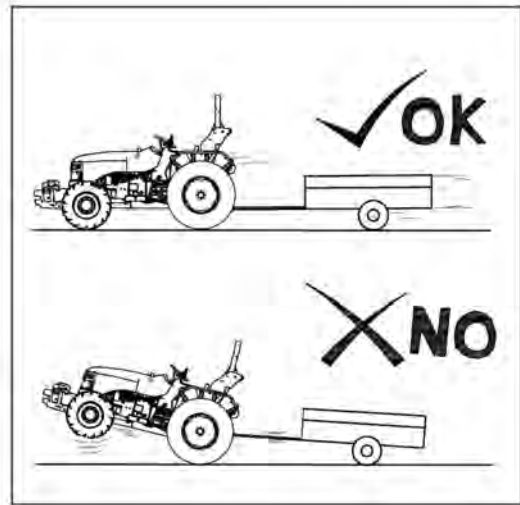

Fig 2.31

ITL000027

- When using attachments or implements with the tractor, be sure to thoroughly read the Operator Instruction Book for that attachment or implement and follow its safety instructions.
- Pull only from the approved drawbar. Towing or attaching to other locations may cause the tractor to overturn (Fig.2.31).
- Improper use of the drawbar, even if correctly positioned, may cause the tractor to overturn to the back.
- DO NOT overload an attachment or towed equipment Use proper counterweights to maintain tractor stability. Hitch loads to the drawbar only.



**WARNING** : A front-end loader (bucket or forks) must be equipped with a suitable restraining device to prevent the load, bales, fence posts, rolls of fence, wires etc.) from rolling down the lift arms into the operator's compartment and crushing the driver when the loader is raised. Inadequately secured objects could also fall and injure bystanders. Do not use implements for different purpose or to handle materials they are not expected to. For the operation of front loaders and relative safety rules, please refer to the Operation Manual of the loader.



**WARNING** : NEVER attempt to unplug the hydraulic connections, or adjust an implement with the engine running or the PTO drive in operation. It may result in serious injury or death.



## 2. WARRANTY & SAFETY NOTES

### 2.32 Road Transport

- Before operating your tractor on a public road, a number of precautions must be taken.
- Familiarize yourself - and comply - with all local bylaws, and national laws appropriate to your tractor.
- Lock brake pedals together.
- Raise all implements to their transport position and lock them in place.
- Place all implements into their narrowest transport configuration
- Disengage the PTO and differential lock.
- Make sure tractor and equipment are equipped with slow moving vehicle (SMV) signs or beacon if the law requires them and that loads do not obscure them or other lights (fig.2.32).
- Make sure any required clearance flags or hazard lights are in place and in working order.
- Make sure you use a proper hitch pin with a clip retainer.
- Clean off all reflectors and road lights, front and rear, and be certain they are in working order.
- Implements mounted on the 3-point hitch and mounted implements projecting from the side need a wider turn radius than trailed implements. Always be sure to keep enough clearance when making a turn.

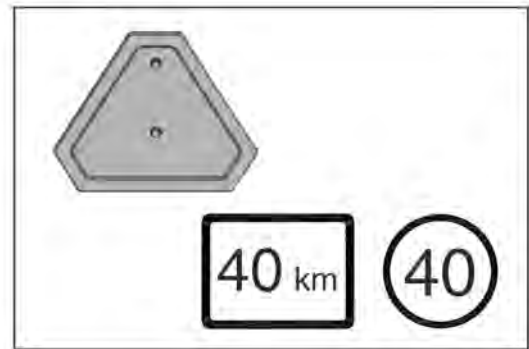

Fig 2.32

ITL000028



**CAUTION:** During road application, do not operate the tractor in 4WD mode in High speed gears.

## 2. WARRANTY & SAFETY NOTES

### 2.33 Road regulations

When operating your tractor on a public road a number of precautions must be taken.

Know the route you are going to travel.

Use flashing lights or beacon when traveling on roads, day or night, unless prohibited by law (Fig. 2.33).

Use caution when towing a load at transport speeds especially if the towed equipment is NOT equipped with brakes.

Observe all local or national regulations regarding the road speed of your tractor.

Use extreme caution when transporting on snow covered or slippery roads.

Wait for traffic to clear before entering a public road.

Beware of blind intersections. Slow down until you have a clear view.

DO NOT attempt to pass at any intersection. Slow down for turns and curve

- Make wide, gentle turns.
- Signal your intent to slow, stop or turn.
- Shift to lower gear before going up or down hills.
- Keep tractor in gear. Never coast with the clutch disengaged or transmission in neutral.
- STAY OUT of the path of oncoming traffic.

### 2.34 Safety-After Operation

When stopping at any time, bring the tractor to a secure halt (DO NOT park on a slope), apply the parking brake, engage the Park Lock (if installed), disengage the PTO, place all gear shift levers in neutral, lower the implement to the ground, stop the engine and remove the key BEFORE leaving the seat.

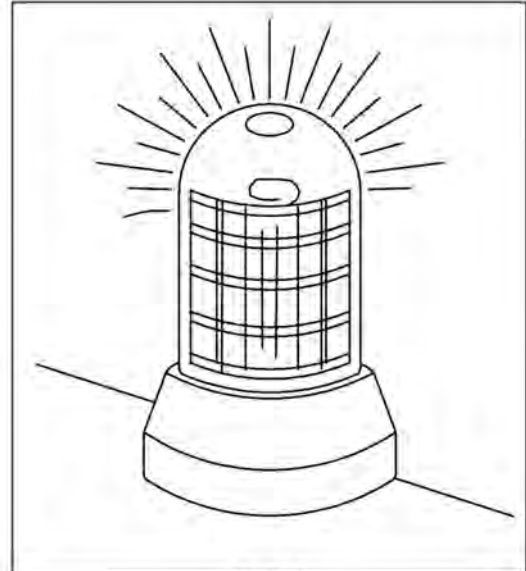

Fig 2.33

ITL000028

- Drive in your correct lane keeping as near to the kerb as possible.
- If traffic builds up behind you, pull off the road and let it go by.
- Drive defensively. Anticipate what other drivers might do.
- When towing a load, start braking sooner than normal and slow down gradually.
- Watch out for overhead obstructions.

## 2. WARRANTY & SAFETY NOTES

### 2.35 Risks deriving from exposure to noise

#### Noise characteristics and measurement

Noise is a pressure variation in an elastic medium, generally the air, produced by the variation of a material body (source) that determines an undesired and often annoying acoustic sensation. Noise is mainly characterized by;

- **Sound intensity or level:** expresses the entity of the pressure variation due to the sound wave. Measured in decibels (dB), It doubles the sound intensity and, thus, the energy that reaches the ear.
- **Frequency:** expresses the number of pressure variations of the wave per second and is measured in Hertz (Hz)- acute noises have high frequencies (2000-4000 Hz or more) while low-pitched noises have low frequencies (250 Hz or less).

#### Noise pathologies

Noise causes hyperdulia or deafness because it destroys the acoustic receptors, nervous cells able to transform the mechanical sound vibrations into nervous impulses that, on reaching the brain, determine the aural sensation. These receptors are irreplaceable if they are destroyed and the resulting damage is irreversible: hyperdulia worsens if exposure to noise continues and does not improve even if this terminates.

Moreover, it is also bilateral since it can be accompanied by annoying buzzing and whistling sounds, and by intolerance to loud noise.

- **How the risk is evaluated:** The higher the sound level and exposure time, the greater the noise risk will be:
- **LAeq:** (Equivalent continuous weighted level A): this is a sound level measurement that takes into account noise fluctuations and the varying sensitivity of the ear to the frequencies: LAeq is measured with a sound level meter;
- **PEL (Personal Exposure Level):** this is a measurement that takes the various noise levels into account along with the time the worker remains on the individual machines or working at determined processes: PEL is calculated mathematically.

The damage is insidious since it proceeds slowly and unexpectedly: in the initial phase, when it is limited to a diminished ability to perceive acute sounds (music, bells) or the spoken voice when there is a background noise, it can only be detected by means of an audiometric test. Pulsating noises of great intensity lasting a very short time are highly damaging since the ear is unable to actuate any physiological protective measures in time. Hyperdulia from noise generally arises after several years of exposure and depends on the PEL (risk almost null below 80 dBA) and on individual characteristics. It is an incurable disease: the only efficacious means of protection against it is prevention.

## 2. WARRANTY & SAFETY NOTES

### Other effects

Noise does not just determine aural sensation. For levels exceeding\* 70 dBA, it causes stress by means of the cerebral integration centers and determines a specific neurovegetative reaction responsible for effects that lead to cardio circulatory and gastro enteric diseases. Amongst these, it is worthwhile noting: an increase in gastric acidity, a decrease in the heart rate, visual range and reflex speed; a sensation of discomfort and weariness with an increased sense of fatigue.

These effects are dangerous because they also increase the risk of accidents.

### Personal equipment to protect against noise

Individual protective equipment attenuates the sound energy transmitted to the ear through the air. This equipment is used when dangerous exposure cannot be avoided in any other way.

There are different types of devices with different attenuating capacities: helmets, ear muffs, ear plugs (Fig.2.35). Helmets and ear muffs offer the greatest protection but they are bulky and inconvenient to wear. They are therefore only of use for exposure to high noise levels but for short periods of time (max. 2 hours).



Fig 2.35

ITL000030

Ear plugs are generally tolerated to a greater extent and are of particular use in the case of lengthy exposure to noise of a lesser intensity.

Always use adequate individual protective equipment to safeguard the hearing.

## 2. WARRANTY & SAFETY NOTES

### 2.36 Safely Handling Batteries

Battery gas can explode. Keep sparks and flames away from batteries. Use a flashlight to check battery electrolyte level.

Never check battery charge by placing a metal object across the posts. Use a voltmeter or hydrometer.

Always remove grounded (-) battery clamp first and replace grounded clamp last.

Sulfuric acid in battery electrolyte is poisonous and strong enough to burn skin, eat holes in clothing, and cause blindness if splashed into eyes.

#### Avoid hazards by:

- Filling batteries in a well-ventilated area
- Wearing eye protection and rubber gloves
- Avoiding use of air pressure to clean batteries
- Avoiding breathing fumes when electrolyte is added
- Avoiding spilling or dripping electrolyte
- Using correct battery booster or charger procedure.
- If acid is spilled on skin or in eyes:

#### Flush skin with water.

1. Apply baking soda or lime to help neutralize the acid.
2. Flush eyes with water for 15-30 minutes.
3. Get medical attention immediately.



**WARNING :** Battery posts, terminals, and related accessories contain lead and lead compounds, chemicals known to the State of California to cause cancer and reproductive harm. Wash hands after handling.



Fig 2.36 (a)

ITL000031

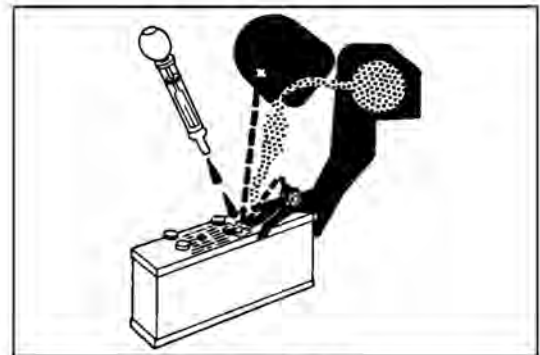

Fig 2.36 (b)

ITL000032

#### If acid is swallowed:

- Do not induce vomiting.
- Drink large amounts of water or milk, but do not exceed 2 Litres.
- Get medical attention immediately.

## 2. WARRANTY & SAFETY NOTES

### 2.37 Handle fuel with care

- It is highly flammable. Do not refuel tractor while smoking or when near open flame or sparks.
- Always stop engine before refueling tractor. Fill fuel tank outdoors.
- Prevent fires by keeping tractor clean of accumulated trash, grease, and debris. Always clean up spilled fuel.
- Use only an approved fuel container for transporting flammable liquids.
- Never fill fuel container in pickup truck with plastic bed liner. Always place fuel container on ground before refueling. Touch fuel container with fuel dispenser nozzle before removing can lid. Keep fuel dispenser nozzle in contact with fuel container inlet when filling.
- Do not store fuel container where there is an open flame, spark, or pilot light such as within a water heater or other appliance.



Fig 2.37

ITL000033

### 2.38 Avoid Hot Exhaust

Servicing machine or attachments with engine running can result in serious personal injury. Avoid exposure and skin contact with hot exhaust gases and components.

Exhaust parts and streams become very hot during operation.

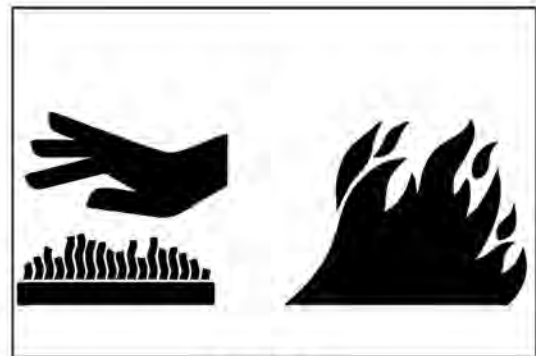

Fig 2.38

ITL000034

## 2. WARRANTY & SAFETY NOTES

### 2.39 PTO Safety

Before attaching, detaching, cleaning or adjusting PTO driven implements, disengage the PTO (first pull the PTO clutch & then neutral the PTO lever), stop the engine remove the key, and make sure that the PTO driveline has stopped.

Be sure everyone is clear of your machine before engaging the PTO. For stationary PTO operation, always place transmission in neutral, engage parking brake and lock both tractor and driving wheels.

When operating mobile PTO driven equipment, never leave the tractor seat until the PTO drive is disengaged, the transmission is in neutral, the parking brake is engaged, the engine shut off and the key removed.



**CAUTION:** Remove PTO cap (A) only when the PTO is to be used.

As soon as PTO-driven implement is removed, re-install cap over PTO stub shaft.

The master shield (B) can be folded up to allow an implement to be connected, but it must be folded down again afterwards.

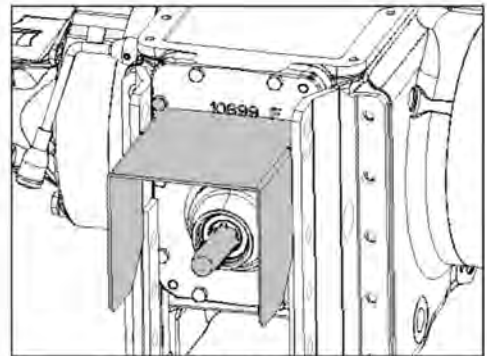

Fig 2.39 (a)

ITL000035



Fig 2.39 (b)

ITL000036

## 2. WARRANTY & SAFETY NOTES



**CAUTION:** Never operate PTO unless the master shield is in the position shown. Switch off the PTO before raising the implement.



Fig 2.39 (c)

ITL000037



**CAUTION:** Before using the PTO, the maximum permissible angle of articulation on the telescoping drive line must be ascertained. During operation, there must be no contact between the PTO guard and the telescoping driveline. This is particularly important when turning corners.



**CAUTION:** Always put a guard (C) on the telescoping drive line and take action to prevent it from turning with the shaft. Do not operate the telescoping drive line unless a guard is installed that covers the PTO shaft completely and does not turn with the shaft.

### Attaching PTO-Driven Implement:

1. Shut off engine and disengage PTO before attaching PTO-driven equipment.



**CAUTION:** High-inertia implements do not come to a standstill the moment the PTO control lever is shifted to the disengaged position. Do NOT approach the implement while it is "coasting down". Do not work on the implement until it has stopped.



**CAUTION:** Before attempting to clean, adjust or lubricate a PTO-driven machine, the TPL, always make sure the PTO is switched off and stopped, the tractor engine is shut off and the ignition key is removed. Turn key off to stop engine.



Fig 2.39 (d)

ITL000038



## 2. WARRANTY & SAFETY NOTES

1. Attach implement to tractor before connecting PTO drive line. Lock TPL in upward position if it is not to be used.
2. Rotate PTO shield upward for clearance. With engine off, turn shaft slightly by hand if necessary to line up splines. Connect drive line to PTO shaft. Pull out on shaft to be sure drive line is locked to PTO shaft. Place PTO shield in downward position.
3. Be sure all shields are in place and in good condition. Never operate PTO unless master shield is properly installed. **WITH ENGINE STOPPED**, check integral shields on drive line by making sure they rotate freely on shaft. Lubricate or repair as necessary.
4. Check carefully for any interference, make sure TPL is locked in the upward position if it is not used.

As far as possible, angles (a) and (b) at the universal joints should be the same at both ends of the Telescoping driveline.

In applications where this is not the case (e.g. sharp turns with PTO engaged), it is recommended to use a continuous-velocity drive shaft.

1. Z-shaped layout
2. W-shaped layout

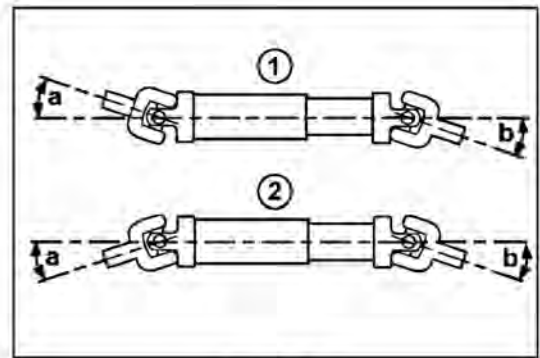

Fig 2.39 (e)

ITL000039

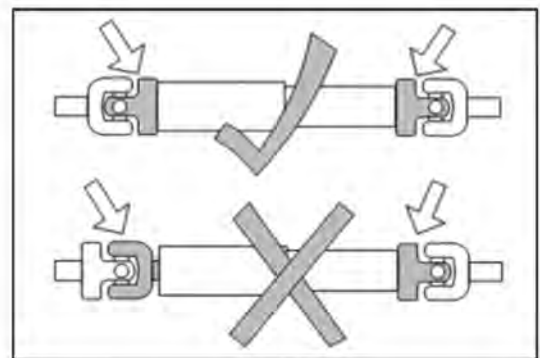

Fig 2.39 (f)

ITL000040

## 2. WARRANTY & SAFETY NOTES

### 2.40 Safety while Operating Loader attachments

- The equipment must only be used by authorised and trained personnel who, beforehand, must read and understand these instructions and become familiar with the equipment controls and their operation.
- Before operation, check all functions of the equipment and attachment going to be used.
- The equipment must be used by people aged more than 18 years, having the qualities required by the national legislation.
- Before or during work, do not take alcoholic beverages, medicines or other substances that may alter your psycho-physical conditions and affect your working abilities.
- The equipment must only be used for the applications intended by the manufacturer. An improper use may cause serious damage and injury.
- Always check the weight and nature of the load to be handled and the stability of the tractor in relation to the ground conditions.
- Couple the equipment only to tractors fitted with adequate rollover protective structures.
- Do not use the equipment on steep slopes.
- Before pressuring the hydraulic circuit of the equipment, make sure that the hydraulic hoses are intact and properly connected.
- Do not use the equipment to lift or transport people (Fig. 2.40 b).
- Do not use the equipment as a working platform.
- Never transit or halt under suspended loads or under parts of the equipment (Fig. 2.40 c) supported solely by hydraulic jacks or ropes.
- Do not use the equipment if problems or anomalous vibrations are noticed.
- Do not use the equipment to handle loads without using an appropriate attachment; for instance, do not use a bucket to lift a round bale. Be very careful to raised loads (Fig. 2.40 d).

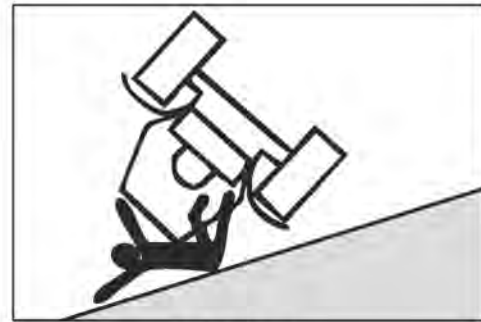

Fig 2.40 (a)

ITL000041

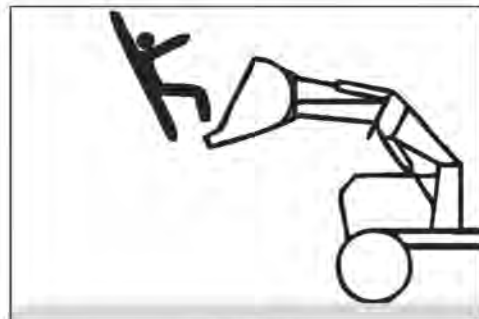

Fig 2.40 (b)

ITL000042

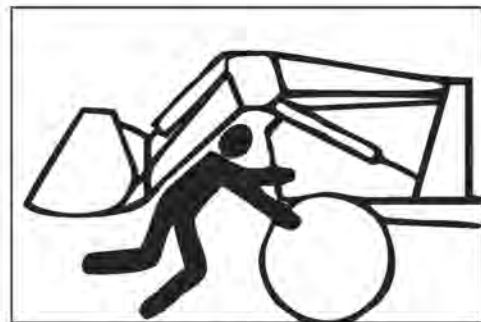

Fig 2.40 (c)

ITL000043



Fig 2.40 (d)

ITL000044

**FOR INSTRUCTIONS AND SAFETY RULES FOR OPERATING LOADER, FOLLOW INSTRUCTIONS AVAILABLE ON LOADER'S OPERATOR MANUAL.**

## 2. WARRANTY & SAFETY NOTES

### 2.41 Avoid contact with Agricultural Chemicals

If pesticide use instructions require respiratory protection, wear an appropriate respirator.

Store the respirator in a closed box or some other type of sealable container, such as a plastic bag.



ITL000045

### 2.42 Limited Use in Forestry Operation

The intended use of tractor when used in forestry operations is limited to tractor-specific applications like transport, stationary work such as log splitting, propulsion, or operating implements with PTO, hydraulic, or electrical systems.

These are applications where normal operation does not present a risk of falling or penetrating objects. Any forestry applications beyond these applications, such as forwarding and loading, requires fitment of application-specific components including Falling Object Protective Structure (FOPS) and/or Operative Protective Structures (OPS).

### 2.43 Safety from Lightning Strike



Lightning strikes injure and kill hundreds of people each year. Follow these precautions to help keep you safe when the weather turns bad:

- As soon as you hear thunder, shut off and put away equipment and move indoors. When you are able to hear thunder, you can be struck by lightning. Lightning can strike even when it's no training.
- The cab of an enclosed vehicle provides some protection from Lightning but a sturdy building provides the best protection.
- Listen to the radio for weather updates and storm warning.

## 2. WARRANTY & SAFETY NOTES

### 2.44 Noise & Vibration Levels

The value of the noise at the operator's ear, measured according to standard 167/2013 (EU) and/or as per Directive 2009/76/EC (1) of the European Parliament and of the Council and the noise of the tractor in motion measured according to Annex VI to Directive 2009/63/EC (2) of the European Parliament and of the Council and/or 167/2013 (EU):

Operator ear level:- Less than 86 dB. Noise at By standard level (when tractor is in motion & when tractor is stationary):- Less than 89 dB.

The value of the vibration level measured according to standard 167/2013 (EU) and/or according to Council Directive 78/764/EEC(3) is less than 1.25 m/s<sup>2</sup>

### 2.45 Safety Labels & its Position on Tractor

Replace missing or damaged safety signs. Use this operator manual for correct safety sign placement.

There may be additional safety information contained on parts and components sourced from suppliers that is not reproduced in this operator manual.

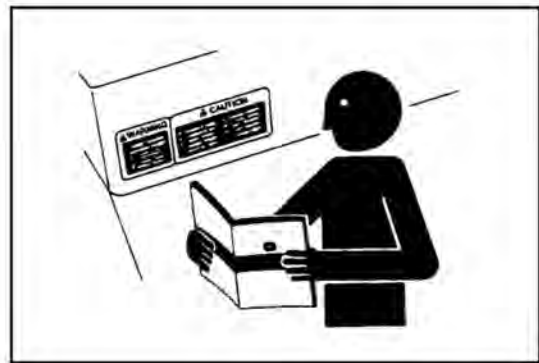

ITL000046

### Safety Labels Location

#### 1. Information Label for Correct Method of using hydraulic lift and general service instructions

Location : Placed on right hand side fender

CORRECT METHODS OF USING LIFT	SERVICE														
<ul style="list-style-type: none"> <li>BRING BOTH LEVER (DRAFT AND POSITION) TOWARDS DOWN POSITION.</li> <li>TAKE LEVER (UP POSITION) TILL LIFT STARTS RAISING, THEN BRING IT TO SLIGHTLY DOWN POSITION.</li> <li>RUN THE TRACTOR IN CORRECT PLOUGHING GEAR AND SPEED.</li> <li>WHILE TRACTOR IS PLOUGHING BRING DRAFT LEVER DOWN VERY SLOWLY UNTIL YOU GET THE RIGHT DEPTH (WITHOUT OVER LOADED) THEN LOCK THE LEVER WITH KNOB.</li> <li>ALWAYS USE THE DRAFT LEVER FULLY UP TO 80% CAPACITY.</li> </ul>	<p>FOR FIRST 10 hrs, OPERATE THE TRACTOR WITHOUT LOAD AND AFTER 10 hrs ON NORMAL LOAD, AFTER 100 hrs AT ANY LOAD.</p> <p>FIRST SERVICE AFTER 40 hrs OF RUNNING:</p> <table border="1"> <tr> <td>1</td> <td>CHANGE ENGINE OIL AFTER EVERY 200 hrs.</td> </tr> <tr> <td>2</td> <td>CLEAN THE PRIMARY ELEMENT AFTER EVERY 200 hrs OF OPERATION OR WHENEVER CHARGE INDICATOR GLOWS ON DASHBOARD. REPLACE PRIMARY ELEMENT AFTER 3 CLEANINGS OR 750 hrs (WHICHEVER EARLIER). CLEAN PRIMARY FILTER ELEMENT BY BLOWING AIR (MAX. PRESSURE 1.2 BAR/POUND) FROM INSIDE. SECONDARY ELEMENT TO BE REPLACED AFTER 3 REPLACEMENTS OF PRIMARY ELEMENT.</td> </tr> <tr> <td>3</td> <td>CHANGE DIESEL PRE - FILTER AFTER EVERY 500 hrs AND MICRO FILTER EVERY 750 hrs.</td> </tr> <tr> <td>4</td> <td>DO NOT CLEAN DIESEL FILTER ELEMENTS.</td> </tr> <tr> <td>5</td> <td>TYRE PRESSURE: FRONT (12.4-38) ON ROAD 180 KPa, ON FIELD 160 KPa. REAR (18.4-50) 150 KPa, 110 KPa.</td> </tr> <tr> <td>6</td> <td>GREASE DAILY, ESPECIALLY FRONT HUB AND REAR AXLE.</td> </tr> <tr> <td>7</td> <td></td> </tr> </table>	1	CHANGE ENGINE OIL AFTER EVERY 200 hrs.	2	CLEAN THE PRIMARY ELEMENT AFTER EVERY 200 hrs OF OPERATION OR WHENEVER CHARGE INDICATOR GLOWS ON DASHBOARD. REPLACE PRIMARY ELEMENT AFTER 3 CLEANINGS OR 750 hrs (WHICHEVER EARLIER). CLEAN PRIMARY FILTER ELEMENT BY BLOWING AIR (MAX. PRESSURE 1.2 BAR/POUND) FROM INSIDE. SECONDARY ELEMENT TO BE REPLACED AFTER 3 REPLACEMENTS OF PRIMARY ELEMENT.	3	CHANGE DIESEL PRE - FILTER AFTER EVERY 500 hrs AND MICRO FILTER EVERY 750 hrs.	4	DO NOT CLEAN DIESEL FILTER ELEMENTS.	5	TYRE PRESSURE: FRONT (12.4-38) ON ROAD 180 KPa, ON FIELD 160 KPa. REAR (18.4-50) 150 KPa, 110 KPa.	6	GREASE DAILY, ESPECIALLY FRONT HUB AND REAR AXLE.	7	
1	CHANGE ENGINE OIL AFTER EVERY 200 hrs.														
2	CLEAN THE PRIMARY ELEMENT AFTER EVERY 200 hrs OF OPERATION OR WHENEVER CHARGE INDICATOR GLOWS ON DASHBOARD. REPLACE PRIMARY ELEMENT AFTER 3 CLEANINGS OR 750 hrs (WHICHEVER EARLIER). CLEAN PRIMARY FILTER ELEMENT BY BLOWING AIR (MAX. PRESSURE 1.2 BAR/POUND) FROM INSIDE. SECONDARY ELEMENT TO BE REPLACED AFTER 3 REPLACEMENTS OF PRIMARY ELEMENT.														
3	CHANGE DIESEL PRE - FILTER AFTER EVERY 500 hrs AND MICRO FILTER EVERY 750 hrs.														
4	DO NOT CLEAN DIESEL FILTER ELEMENTS.														
5	TYRE PRESSURE: FRONT (12.4-38) ON ROAD 180 KPa, ON FIELD 160 KPa. REAR (18.4-50) 150 KPa, 110 KPa.														
6	GREASE DAILY, ESPECIALLY FRONT HUB AND REAR AXLE.														
7															

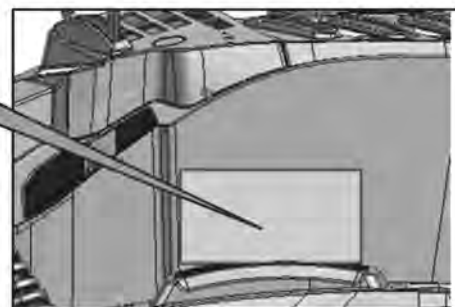

ITL000047

## 2. WARRANTY & SAFETY NOTES

### 2. Safety Label for location of Emergency Exit

Location in Cabin variants: Placed on back side Driver's seat on emergency exit window

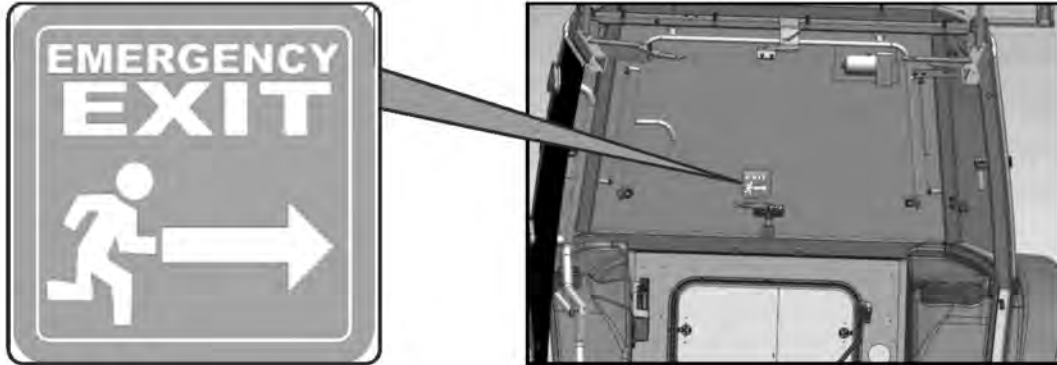

ITL000048

### 3. Safety Labels for Carefully reading operator's manual before handling the tractor.

Location : Placed On left Fender

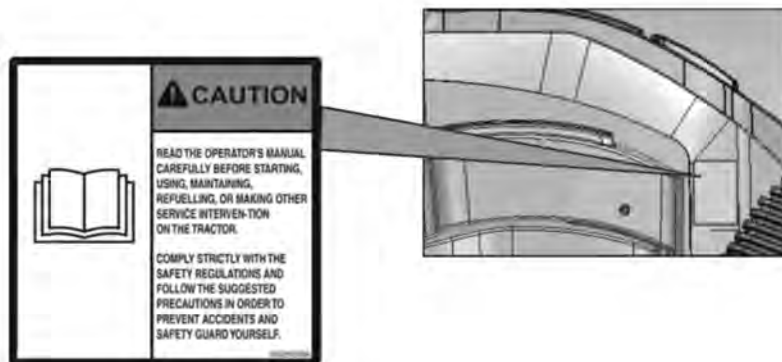

ITL000049

### 4. Safety Labels as per following details:

Location : Placed on LHS Console

Observe instructions & safety rules when operating.

Consult technical manual for proper service procedures.

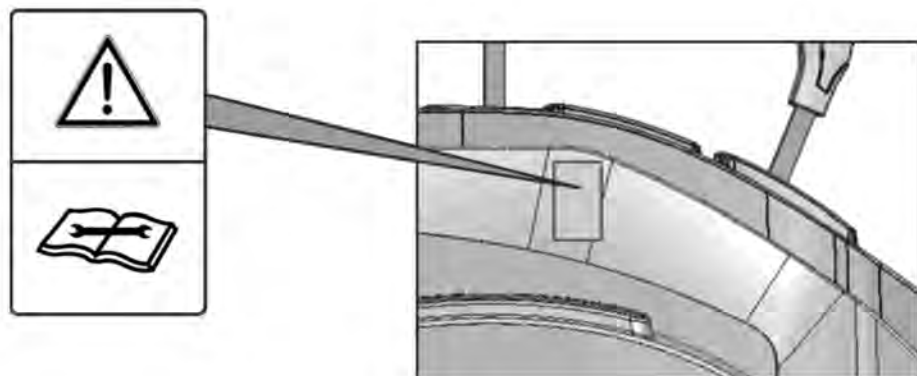

ITL000050

## 2. WARRANTY & SAFETY NOTES

### 5. Safety Label to Read & Understand Operator's Manual Instructions

Location: Placed on LHS Fender

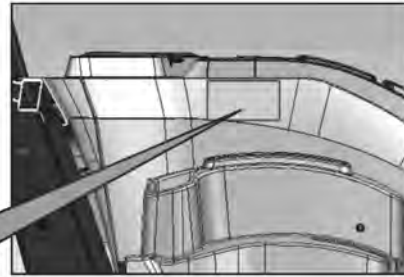
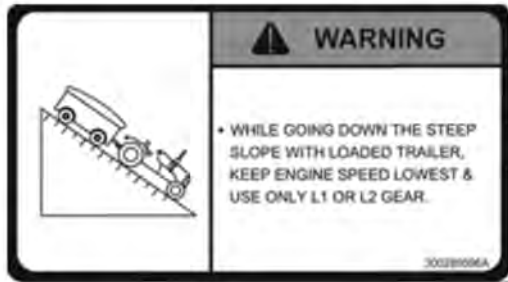

ITL000051

### 6. Location: Placed on LHS Main Console

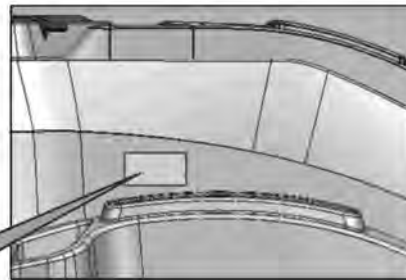
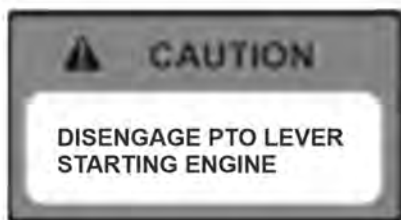

ITL000052

### 7. Location: Placed on rear Hood assembly

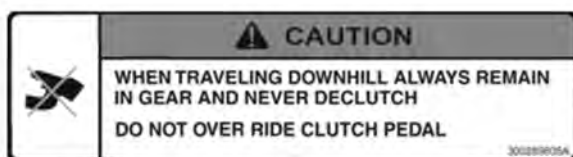

ITL000053

## 2. WARRANTY & SAFETY NOTES

8. Location: Placed under driver seat



ITL000054

9. Location: Placed on RHS Fender under rear Stop Light



ITL000055

10. Location: Placed on LHS Main Console



ITL000056

## 2. WARRANTY & SAFETY NOTES

11. Location: Placed on RHS Main Console



ITL000057

12. Location: Placed on RHS Main Console



ITL000058

13. Location: Placed on RHS Main Console



ITL000059



## 2. WARRANTY & SAFETY NOTES

14. Location: Placed on RH main Console

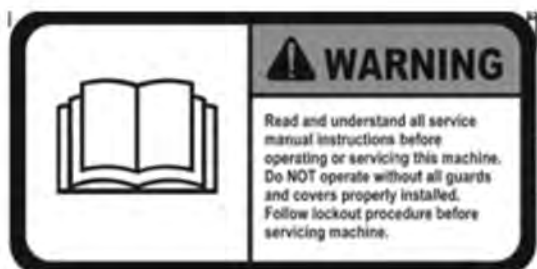

ITL000060

15. Location: Placed on ROPS U Beam



ITL000061

## 3. INSTRUMENTS AND CONTROLS

### 3.1 Tractor Controls (Platform/Cabin Tractor)

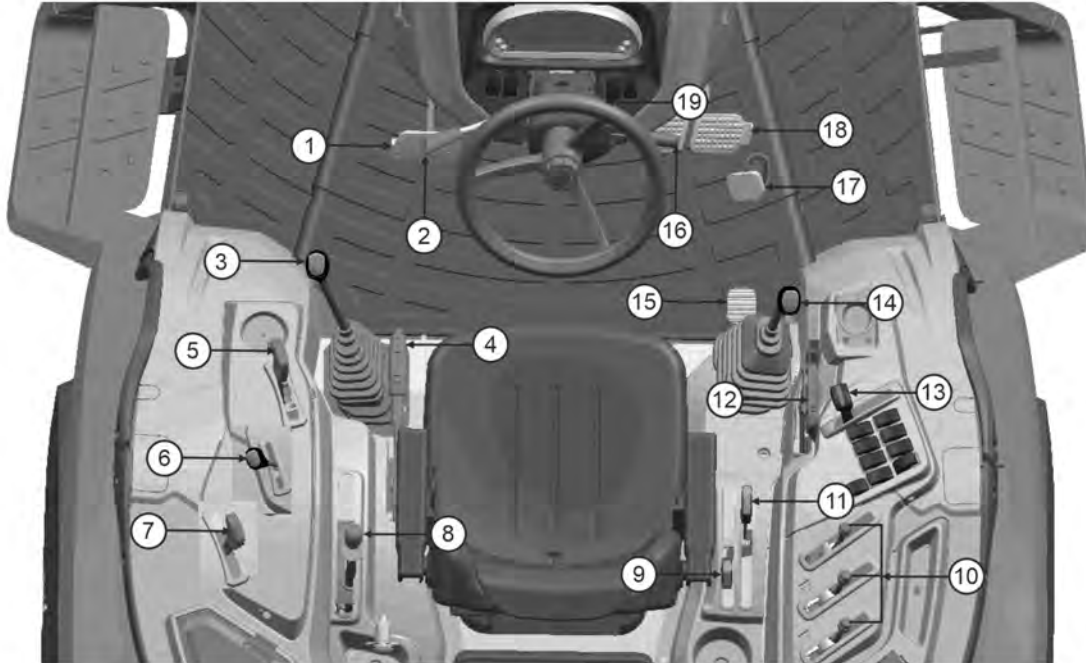

Tractor Controls (Platform/Cabin tractor)

ITL000062

- |                             |                            |
|-----------------------------|----------------------------|
| 1. Clutch Pedal             | 11. Position Control Lever |
| 2. Forward/Reverse Lever    | 12. Liftomatic Lever       |
| 3. Range Lever              | 13. Hand Throttle Lever    |
| 4. Parking Lever            | 14. Gear Speed Lever       |
| 5. GPTO/LPTO Lever          | 15. Diff-Lock Pedal        |
| 6. 2WD-4WD Lever            | 16. Combination Switch     |
| 7. 540/540E Lever           | 17. Foot Accelerator Pedal |
| 8. IPTO Lever               | 18. Brake Pedal            |
| 9. Draft Control Lever      | 19. Steering Wheel         |
| 10. Hydraulic Control Lever |                            |

### 3. INSTRUMENTS AND CONTROLS

**NOTE:** Consult the Operation chapter for instructions on how to correctly use the controls.

#### 3.2 Instrument Panel



Instrument Panel

- |                                  |                             |                               |
|----------------------------------|-----------------------------|-------------------------------|
| 1– RPM Meter                     | 12– 540/540E PTO            | 23– Turn Trailer              |
| 2– OBD / MIL/ Diagnostic         | 13– EH Diff Lock (Optional) | 24– Water in Fuel             |
| 3– System SVS                    | 14– High Beam               | 25– Digital Clock             |
| 4– Work Lamps                    | 15– Temperature Gauge       | 26– Low Brake Oil             |
| 5– Battery Charging              | 16– Cruise On (Optional)    | 27– Engine Preheat            |
| 6– Engine Oil Pressure           | 17– Fuel Gauge              | 28– Left Turn                 |
| 7– Air Filter Clog               | 18– Auto PTO (Optional)     | 29– Parking Brake             |
| 8– 4 Wheel Drive                 | 19– Vehicle Speed           | 30– Final OK Selection Button |
| 9– DPF Regeneration              | 20– Hour Meter              | 31– Menu Button               |
| 10– DPF Regeneration Inhibit     | 21– Error Codes             | 32– Scroll Up Button          |
| 11– High Exhaust Gas Temperature | 22– Right Turn              | 33– Scroll Down Button        |

## 3. INSTRUMENTS AND CONTROLS

### 3.2.1 RPM Meter

Needle of this meter indicates speed of engine in revolution per minute. The pointer should never reach the Red zone which shows excessive engine speed.



ITL000064

### 3.2.2 OBD / MIL/ Diagnostic

This indicator glows when there is any malfunctioning in CRDI system.

**Note :** Contact your nearest dealer if this indicator glows.



ITL000065

### 3.2.3 System SVS Lamp

This indicator glows when there is any error in CRDI system.

**Note :** Contact your nearest dealer if this indicator glows.



ITL000066

### 3.2.4 Plough Lamp (Work Lamp) Indicator

This indicator glows when plough lamp is in ON condition.



ITL000067

### 3.2.5 Battery Discharge Warning Light

This indicator indicates that either battery is being charged or not. It will glow when Ignition switch is ON but engine is OFF. Indication will go off when engine is start/running.

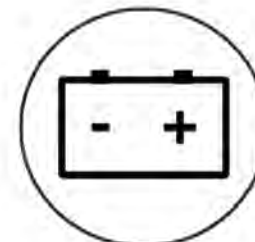

ITL000068

## 3. INSTRUMENTS AND CONTROLS

### 3.2.6 Engine Oil Pressure Indicator

If the oil pressure in the engine goes below the prescribed level, this indicator will glow. If this should happen during operation, and it does not go off when the engine is accelerated to more than 1000 rpm, check level of engine oil.

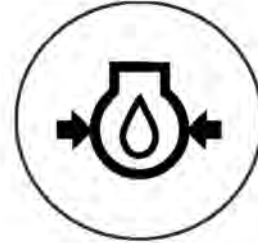

ITL000069

### 3.2.7 Air Filter Clogging Indicator

The light will glow when the air filter gets clogged. Clean the air cleaner element immediately with air pressure if this light is glowing



ITL000070

### 3.2.8 4WD Engage Indicator

This indicator will glow when four wheel drive (4WD) is engaged.

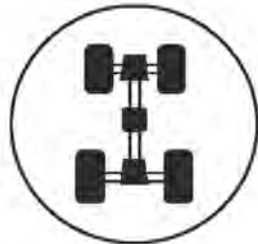

ITL000071

### 3.2.9 DPF Regeneration

It glows when after treatment diesel particulate filter (DPF) requires regeneration.



ITL000072

### 3.2.10 DPF Regeneration Inhibit

Its glows when DPF regeneration inhibit switch is ON to stop the DPF regeneration.



ITL000073

## 3. INSTRUMENTS AND CONTROLS

### 3.2.11 High Exhaust System Temperature

It glows when high exhaust temperature may exist due to after treatment regeneration.



ITL000074

### 3.2.12 PTO 540 Indicator

This indicator glows on engagement of 540 PTO lever. When tractor is in stationary condition and PTO is ON then it display PTO rated RPM and when tractor is in running condition and PTO is ON then it will display PTO actual RPM.



ITL000075

### 3.2.12(a) PTO 540E Indicator

This indicator glows on engagement of 540 Economy PTO lever. When tractor is in stationary condition and PTO is ON then it display PTO rated RPM and when tractor is in running condition and PTO is ON then it will display PTO actual RPM..



ITL000076

### 3.2.13 EH Diff Lock (Optional)

It glows when differential lock switch is ON to lock the differential.



ITL000077

### 3.2.14 High Beam Indicator

This light glows when Head Lights are in high beam mode.

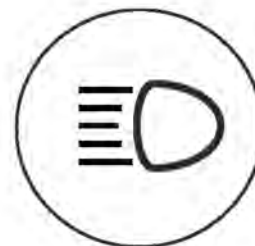

ITL000078

## 3. INSTRUMENTS AND CONTROLS

### 3.2.15 Temperature Gauge

This indicator glows when engine coolant temperature goes high, means engine is overheating.



ITL000079

### 3.2.16 Cruise ON (Optional)

It glows when cruise control switch is activated by operator.

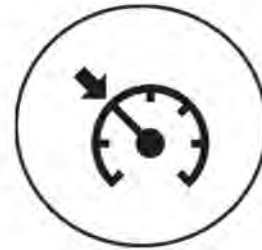

ITL000083

### 3.2.17 Fuel Gauge

When the pointer moves into the “0” zone, it shows there are less fuel in the fuel tank.

#### Warning Light (A) for Fuel Gauge Error:

Turns on: Red zone (0 to 1/8 area)

Blinks: When sensor is open circuit, needle is at empty

Off: Short circuit, needle at empty position



ITL000084

### 3.2.19 Vehicle Speed

This shows vehicle speed after selection of correct tyre sizes.

#### Procedure for selection of Tyre sizes:

- Km/Hour is default mode.
- Press and hold bottom left button (down) and by press and release upper right button (OK) can change mode from Km/h to Mph or Mph to Km/h.
- If no button is pressed for 2 seconds, then current selection mode will be saved.
- Whenever ignition is ON, it will display last selected mode.



ITL000080

## 3. INSTRUMENTS AND CONTROLS

### Tyres type Setup:

The instrument gives possibility to set 10 different tyre types. Each tyre has its own rolling circumference used to compute the vehicle speed. To access the setting screen you have to press both buttons on the left at the same time and hold them down for 5 seconds.

After this procedure, below screen for tyre type setup will be displayed:

The user can scroll down the list using left arrow buttons and select the desired tyre type, to confirm the selection user has to press the upper button on the right. After this instrument goes back to main screen. To abort the procedure (and keep the previous setting). The user has to press the lower button on right.

At first access the top line is selected, after the first time, the previously set tyre will be selected. By default (if no tyre is selected, e. g. at first start up) the instrument uses 16.9x30 TR 135 tyre.

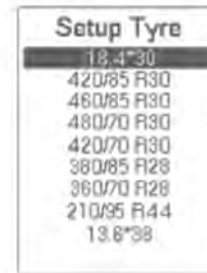

ITL000091

### 3.2.20 Hour Meter

Hour meter indicates the number of hours worked by the engine.

**NOTE:** Hour meter may be defer from actual hour (as per Clock) this is purely depended on Engine RPM.



ITL000081

### 3.2.21 Error Codes

This display will show error codes related to CRDI system, if any occur.

**Note :** Contact your nearest dealer if this indicator glows.



ITL000082



## 3. INSTRUMENTS AND CONTROLS

### 3.2.22 Right Turn Indicator

It glows when the right side indicator is switched ON.

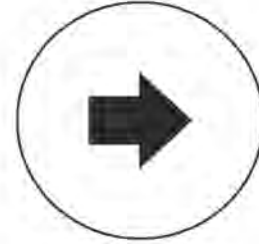

ITL000085

### 3.2.23 Turn Trailer Indicator

This indicator glows when left or right trailer indicator is ON.



ITL000086

### 3.2.24 Water in Fuel Indicator

It indicates the presence of water in fuel and glows when the level of water in spin on filter increase and there is need of draining water from the water separator.



ITL000087

### 3.2.25 Digital Clock

Menu button at bottom right side is used for time setting of the clock.

#### Procedure for time setting:

- When you press the bottom button on the right you access the menu page in which you can set up the time. Hour field is selected automatically as in image as follows:

- By pressing the up arrow (left buttons) the number is incremented by 1, by pressing the down arrow it is decremented by 1. If the button is held pressed the increment/decrement is fast. Data range is 0-23. From 23 if up button is pressed, the number changes to 0. From 0 if down button is pressed, the number changes to 23. By pressing the upper right button the hour value



ITL000088



ITL000089

## 3. INSTRUMENTS AND CONTROLS

is confirmed and the selection is moved to the minute's field.

The procedure to set minutes is the same as described for hours. Data range is 0-59.

At the end of setting, by pressing the upper button on the right, the procedure is ended. Clock hour is saved and the instrument cluster goes back to normal operating screen.

If the lower button on the right is pressed (instead of upper button), time set procedure would interrupt, the instrument cluster goes back to normal operating screen and clock time is not saved (it keeps the previous one).



ITL000090

### 3.2.26 Low Brake Oil Indicator

This indicator glows when the oil level in brake oil tank goes below the prescribed level.



ITL000092

### 3.2.27 Engine Preheat Indicator

This indicator glows when ignition heater is ON at second position of starting key.

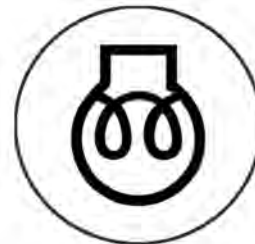

ITL000093

### 3.2.28 Left Turn Indicator

It glows when the left side indicator is switched ON.



ITL000094

## 3. INSTRUMENTS AND CONTROLS

### 3.2.29 Parking Brake Indicator

This indicator indicates engagement of parking brakes.



ITL000095

### 3.2.30 Final OK Selection Button

This button is used to confirm selected option as final.

**IMPORTANT:** If the engine temperature is too high, do not switch it off. If the temperature gauge stays in Hot zone, identify the cause immediately and seek expert advice if necessary.

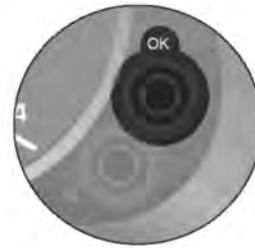

ITL000096

### 3.2.31 Menu Button

This button is used to select Menu option.



ITL000097

### 3.2.32 Scroll Up Button

This button is used for up scrolling of selected options from menu.



ITL000099

### 3.2.33 Scroll Down Button

This button is used for down scrolling of selected options from menu.



ITL000098

## 3. INSTRUMENTS AND CONTROLS

### 3.3.a Dashboard Controls (Platform/Cabin Tractor)

- 1– Hazard Switch
- 2– Battery ON-OFF

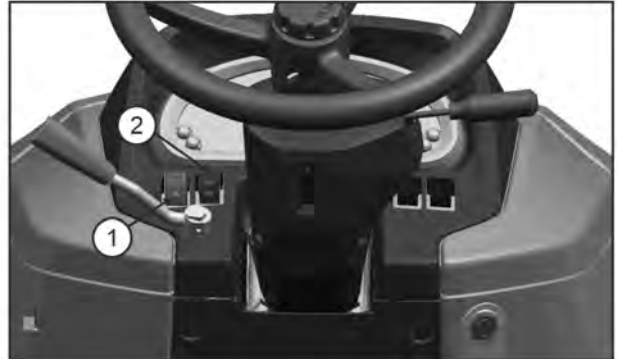

ITL000100

### 3.3.b RH Fender Mounted Controls Switch (Platform Tractor)

- 1– DPF Regeneration/Inhibit Switch
- 2– Inducement Override Switch
- 3– Beacon Light Switch
- 4– Rear Work Lamp Switch
- 5– GND / ENG RPM Switch
- 6– PTO Stabiliser Switch
- 7. PTO External Control Switch
- 8– Signature Light Switch



ITL000101



ITL000102

## 3. INSTRUMENTS AND CONTROLS

### 3.3.c RH Fender Mounted Controls Switch (Cabin Tractor)

- 1– DPF Regeneration/Inhibit Switch
- 2– Inducement Override Switch
- 3– GND / ENG RPM Switch
- 4– PTO Stabiliser Switch
- 5– PTO External Control Switch
6. Signature Light Switch



ITL000103

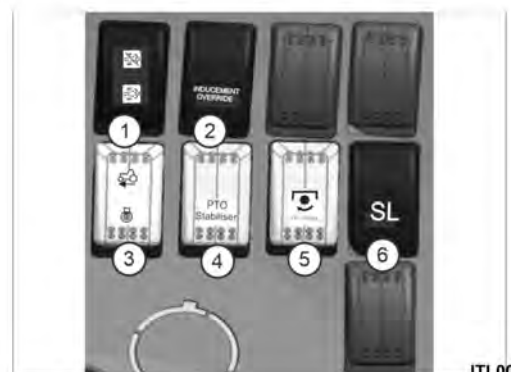

ITL000104

### 3.3.d Roof Mounted Switch (Cabin Tractor)

- 1– Revolving Light Switch
- 2– Front Wiper Switch
- 3– Rear Washer Switch
- 4– Front Washer Switch
- 5– Rear Work Lamp Switch
- 6– Front Work Lamp Switch



ITL000105

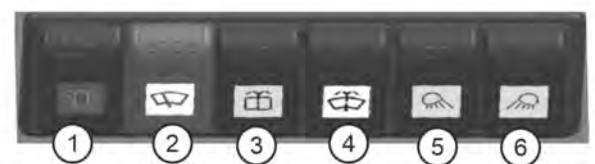

ITL000106

## 3. INSTRUMENTS AND CONTROLS

### 3.3.1 Battery Cut-Off Switch

It locates on dash board to switch ON & OFF the Battery Supply. It is auto return type of switch. Minimum time gap between pressing ON & OFF switch should be 5 seconds.

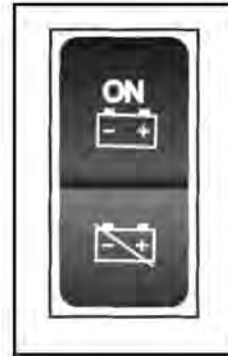

ITL000107

### 3.3.2 Hazard Warning Switch

It locates on dash board to switch ON & OFF the hazard light.

Purpose of the hazard switch is as follows :

- All the four indicator lights blinking indicates that driver has no control on tractor.
- Mechanical defects in the tractor.

Push this switch to blink all indicators in HAZARD situation to alert others.



ITL000108

### 3.3.3 Beacon Light Switch

Its locate on the right fender for platform tractor and locates on the roof for cabin tractor. and This switch is used to ON/OFF the Beacon Light (Revolving Light) mounted on tractor.



ITL000109

### 3.3.4 Rear Work Lamp Switch

Its locate on the right fender of the tractor to ON & OFF the rear work lamp.



ITL000110

## 3. INSTRUMENTS AND CONTROLS

### 3.3.5 DPF Regeneration/Inhibit Switch

Its locate on the right fender of the tractor to start/stop the manual regeneration process.

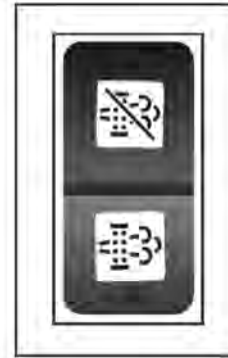

ITL000111

### 3.3.6 PTO Stabiliser

Its locate on the right fender of the tractor to PTO rpm will remain stable irrespective of change in Engine Load.



ITL000112

### 3.3.7 PTO Control Switch

When this switch ON, Operator can get up the driver seat after park brake applied to use the stationary PTO application.



ITL000113

### 3.3.8 Signature Lamp

Its locate on the right fender of the tractor to ON & OFF the rear work lamp.



ITL000114

## 3. INSTRUMENTS AND CONTROLS

### 3.3.9 GND/ENG RPM

Its locate on the right fender of the tractor to select limit of RPM of engine or ground speed with max limiter switch.



ITL000115

### 3.3.10 Inducement Override Switch

Its locate on the right fender of the tractor. During inducement period the MIL lamp blinks, engine power derates and rpm reduced.

**Follow the below procedure to override the inducement:**

- During engine start condition, press the switch for 5 seconds. Tractor will perform as earlier till 30 minutes until causes of inducement is rectified.
- If causes is not rectified then inducement will reoccur after 30 minutes. Then to override the inducement, turn Off the engine and ignition switch for 2 minutes.
- Restart the engine and press the inducement switch for 5 seconds.
- The inducement override is allowed for only 3 times.



ITL000116

**Note: If causes will not rectified, visit your nearest authorized dealer to rectify the causes.**



# 3. INSTRUMENTS AND CONTROLS

## 3.4 Roof Mounted Switches for Cabin Tractor

### 3.4.1 Beacon Light Switch

Its locates on the roof of cabin tractor. and This switch is used to ON/OFF the Beacon Light (Revolving Light) mounted on ROPS.



ITL000117

### 3.4.2 Front Wiper

Its locates on the roof of cabin tractor.

2 Speed switch is provided to operate front Wiper Blade.

**Position 1– Slow Speed**

**Position 2– High Speed**



ITL000118

### 3.4.3 Rear Washer

Its locates on the roof of cabin tractor. Press and hold the switch for spray of water on Windshield rear, and Release the switch it will automatically turn OFF



ITL000119

### 3.4.4 Front Washer

Its locates on the roof for cabin tractor. Press and hold the switch for spray of water on Windshield front, and Release the switch it will automatically turn OFF



ITL000120

# 3. INSTRUMENTS AND CONTROLS

## 3.4.5 Rear Work Lamp

Its locates on the roof of cabin tractor. Press the switch to Switch-ON the Rear Work Lamps.



ITL000121

## 3.4.6 Front Work Lamp

Its locates on the roof of cabin tractor. Press the switch to Switch-ON the Rear Work Lamps.



ITL000122

## 3.5 Ignition (Starting) Switch

Starting (Ignition) Switch has following functions:

Sr.	Symbol	Function
A.		Ignition OFF
B.		Ignition ON
C.		START

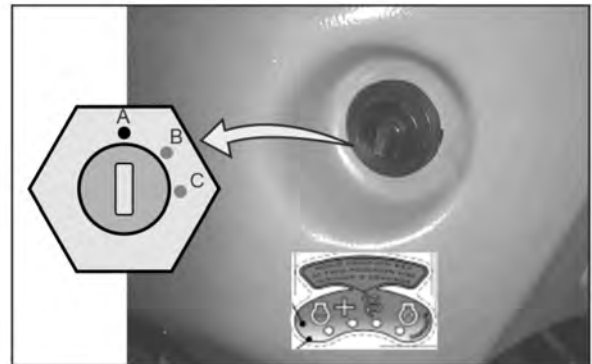

ITL000113

### 3. INSTRUMENTS AND CONTROLS

#### Roof Mounted Interior for Cabin Tractor

- A. Music System
- B. Digital AC Control Panel
- C. Switch Panel
- D. Dome Lights / Door Light
- E. Fuses
- F. Speaker
- G. AC Suction Grill
- H. AC Discharge Louvers
- I. Foldable Sun Shade

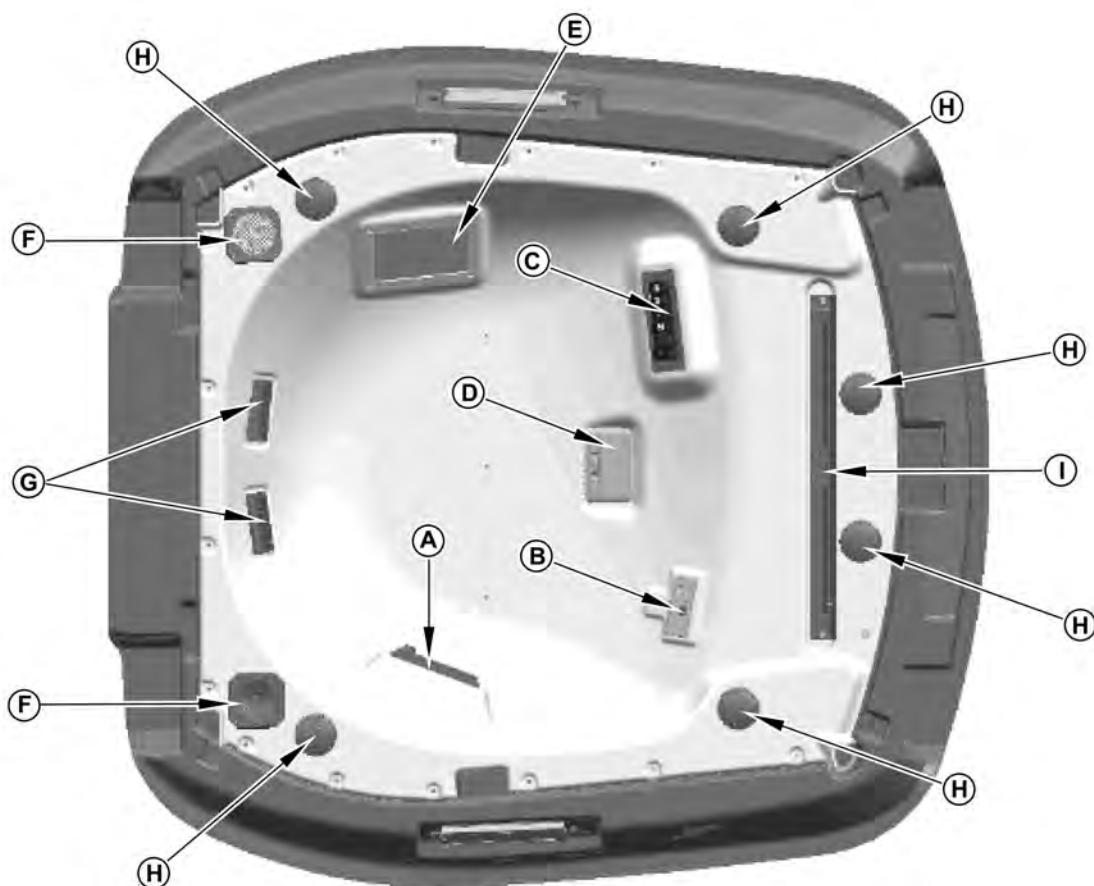

ITL000254

### 3. INSTRUMENTS AND CONTROLS

#### Music System

Ceiling fitted detachable front panel stereo support with 02 speakers.



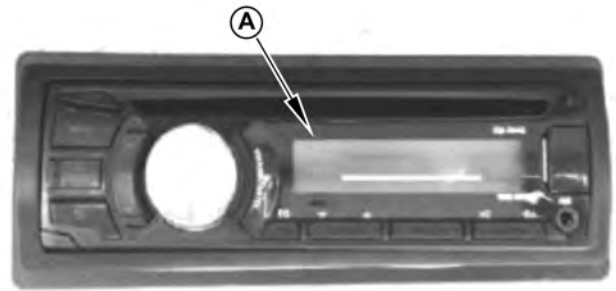



Refer operator manual of music system for detail.



ITL000262

#### Digital AC Control Panel

AC control panel is mounted in sealing on left hand side.

-  Fan — 3 Speed ( X , XX, XXX )
-  A/C - Air Conditioning Switch
-  Temperature Control Up
-  Temperature Control Down
-  Heaters Switch
-  Digital Temperature Display

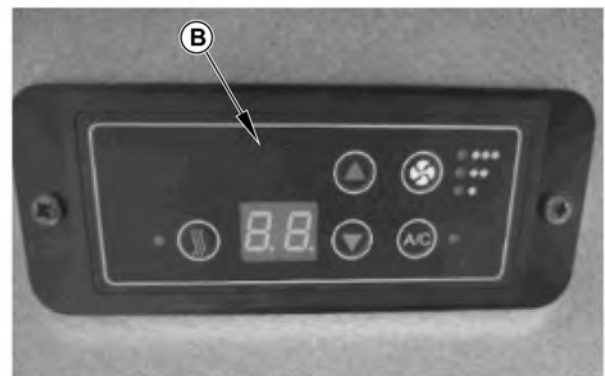

ITL000255

### 3. INSTRUMENTS AND CONTROLS

#### Switch Panel

Field light switches (C) are fitted in roof mounted panel.

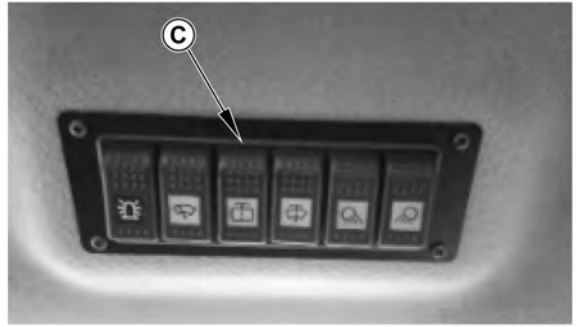

ITL000265

#### Dome Light

Dome light (D) is fitted on front roof panel. Slide the Knob (E) to required position.

ON : Turns on the Dome light

DOOR : Light comes on when door is opened and off when door is closed.

OFF : Turns off the Dome light

**NOTE : Before exiting cab turn the cabin light to OFF or DOOR position.**

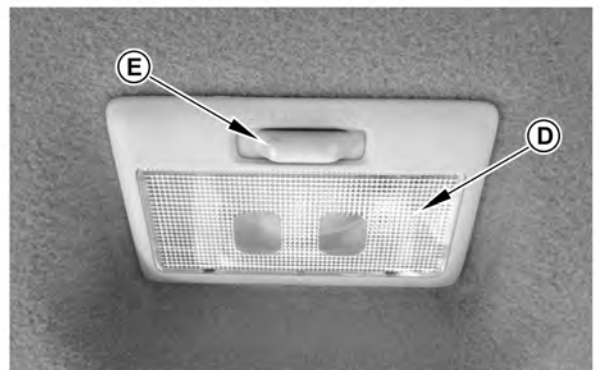

ITL000264

#### Speaker

Speaker (F) mounted on roof left and right rear corner.

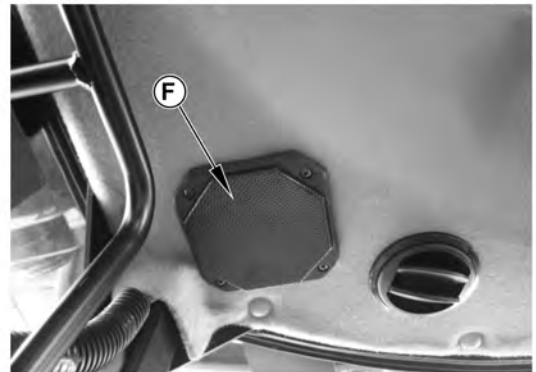

ITL000267

#### AC Suction Grill

AC Suction Grill (G) located on roof.

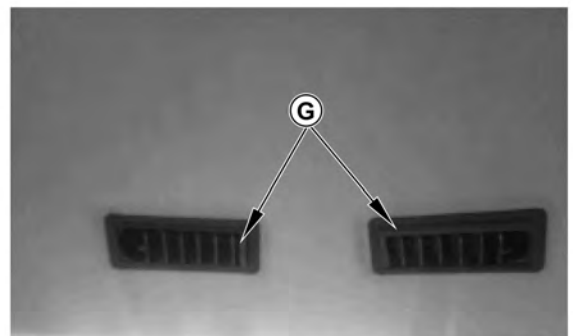

ITL000266

## 3. INSTRUMENTS AND CONTROLS

### AC Discharge Louvers

AC Discharge Louvers (H) mounted on roof (Front and Rear)

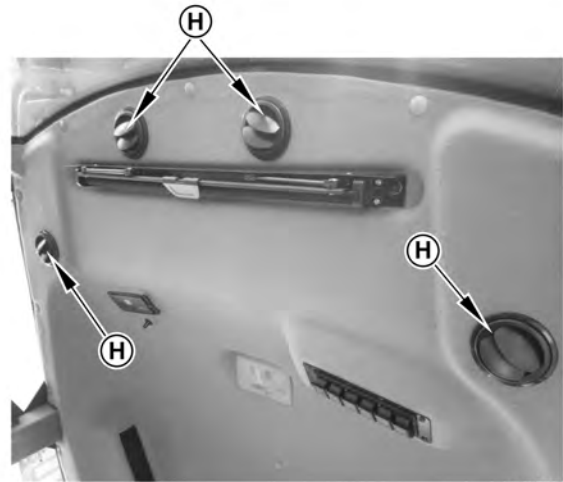

ITL000263

### Foldable Sun Shade

To open foldable sun shade (I) pull down lever (J) and leave it in suitable opened position.

To close press the button (K). It will automatically roll in.

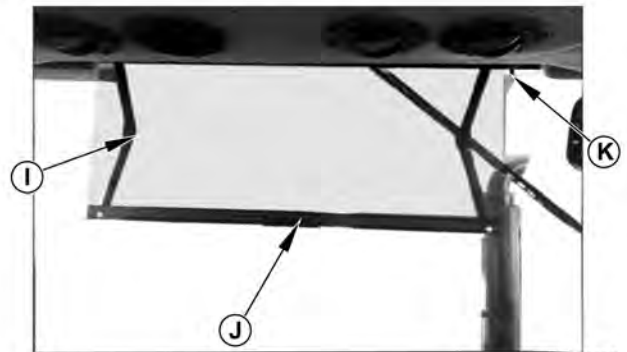

ITL000268

### Fuse Box

Fuse box (L) mounted on right side of roof.

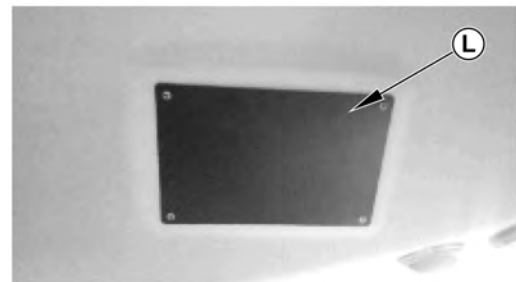

ITL000269

### Rear Wiper

Rear wiper switch (M) is located near the wiper motor fitted at rear wind screen left corner.

Press Red color switch (M) to operate wiper blade.

### Rear Wiper Motor

Rear Wiper Motor (N) located on Left side corner of rear Windscreen.

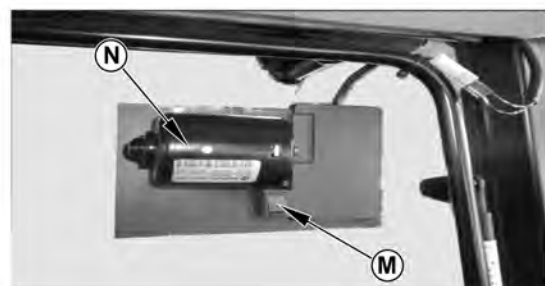

ITL000270

# 3. INSTRUMENTS AND CONTROLS

## 3.6 Fuse Boxes for Platform and Cabin

Fuse boxes are mounted front of the radiator side. If an electrical failure occurs, check and rectify the problem and then replace the blown up fuse with genuine fuse of specified rating.

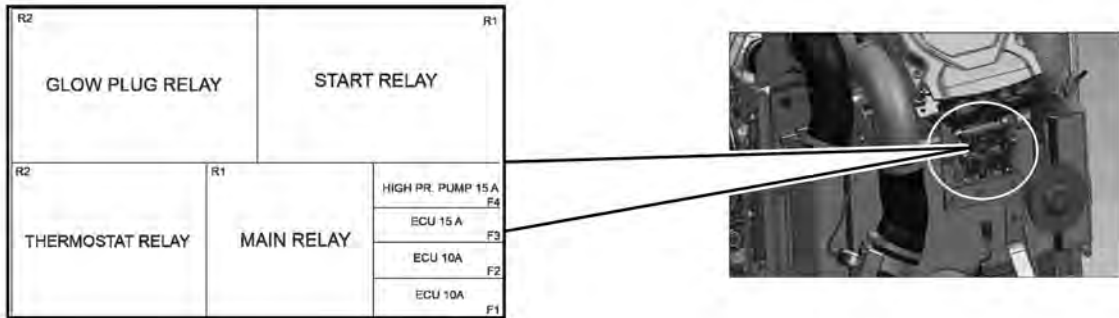

ITL000125

### 3.6.1 Fuse Boxes for Cabin Tractor

Fuse boxes are mounted top of the roof. If an electrical failure occurs, check and rectify the problem and then replace the blown up fuse with genuine fuse of specified rating.

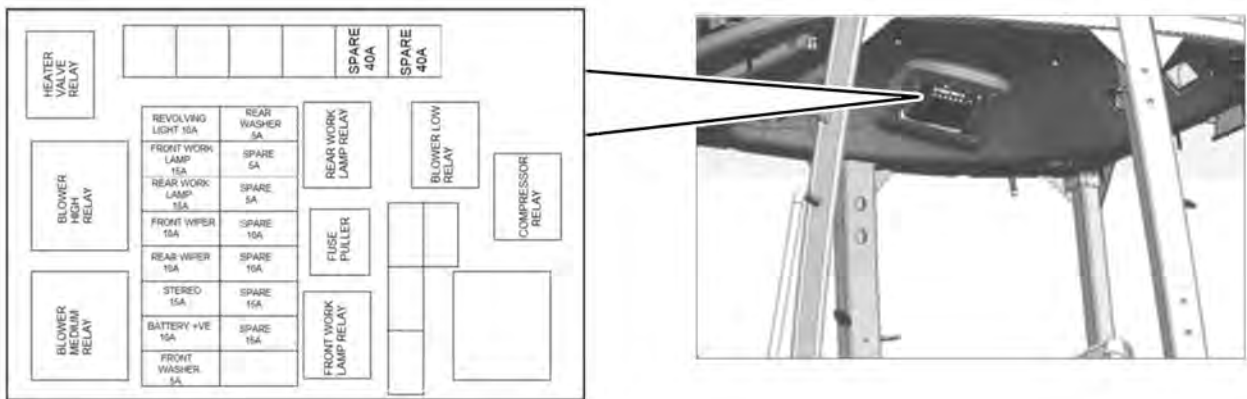

ITL000126

Fuse boxes are mounted on right side of the dash board. If an electrical failure occurs, check and rectify the problem and then replace the blown up fuse with genuine fuse of specified rating.

### 3. INSTRUMENTS AND CONTROLS

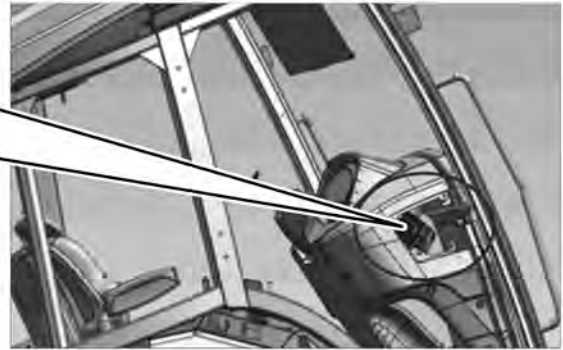
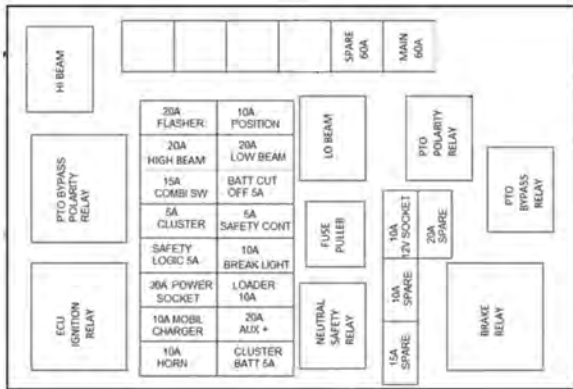

ITL000127

#### 3.6.2 Fuse Boxes for Platform Tractor

Fuse boxes are mounted on right side of the dash board . If an electrical failure occurs, check and rectify the problem and then replace the blown up fuse with genuine fuse of specified rating

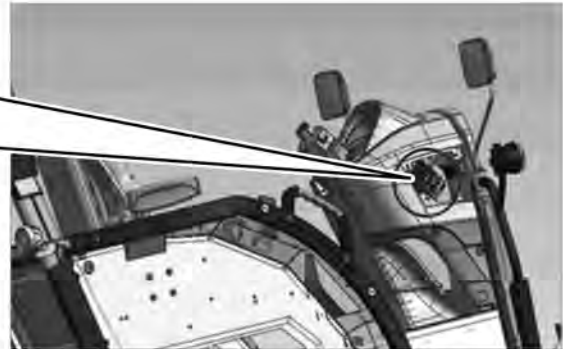
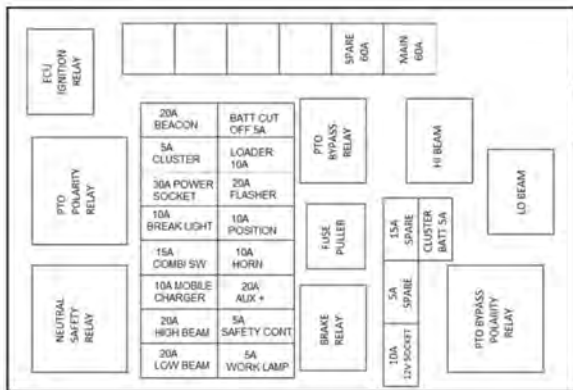

ITL000128



# 3. INSTRUMENTS AND CONTROLS

## 3.7 Combination Switch (Lighting, Turn Signals, Horn Control Lever)

This control lever is located on the right hand side of dashboard. Operate the lever as described below.

**Lighting Operation :** To turn the lights 'ON' or 'OFF' twist the middle portion of lever in anticlock wise direction.

There are three position:

- In '**OFF**' position all lights are OFF (Fig. 3-7a).
- In '**MIDDLE**' position, Fig. 3-7 (b) with ignition switch ON the parking lights, licence lamp and instrument light are 'ON' But headlights are 'OFF'
- In '**THIRD position**', Fig. 3-7 (c) with ignition switch ON, Headlights (Low Beam) comes on in addition to other lights. Push this Lever downward for High Beam. The High Beam Indicator Illuminates in blue color in Instrumental panel.

**Passing Light**, Fig. 3-7 (d): To flash the headlights momentarily, pull the lever all the way up and hold it there. It will return back to the **OFF** position when released.

**NOTE :** Passing light will glow either Head light is turned ON or OFF.

**Turn Signals**, Fig. 3-7 (e)

Push the lever forward for Left hand Indicator pull the lever toward you for Right hand Indicator.

**Horn Switch**, Fig. 3-7 (f)

Press the push button at the end of this lever to blow horn.



Fig 3.7 (a)

ITL000129

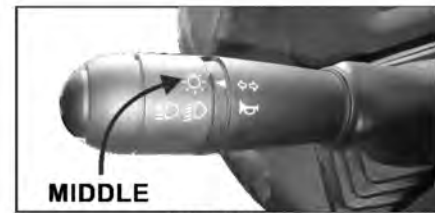

Fig 3.7 (b)

ITL000130



Fig 3.7 (c)

ITL000131



Fig 3.7 (d)

ITL000132



Fig 3.7 (e)

ITL000133



Fig 3.7 (f)

ITL000134

## 3. INSTRUMENTS AND CONTROLS

### 3.8 DPF System









#### Type of DPF Regeneration (RGN) :

**Automatic/active regeneration** :The ECU will periodically activate thermal management system, which controls the fuel injections to increase the exhaust temperature to burn off the accumulated Soot, this is entirely transparent to the driver.

**Operator assisted/Manual regeneration** :if an automatic regeneration cannot be conducted, the ECU alerts the driver to execute a stationary regeneration cycle. Once initiated by the driver, the engine calibration and thermal management features increase the exhaust gas temperature, which may require approximately 30min.

**Service regeneration** :If the DPF is not regenerated by the driver/operator and the soot load increases to a level that threatens an uncontrolled regeneration and damage to the filter, the ECU displays an engine malfunction message alerting the driver to go to a service station. There the DPF can be regenerated using the vehicle diagnostic tester ,or else it has to be removed from the vehicle and cleaned using specialized DPF cleaning equipment.

#### DPF Regeneration Strategy :

Sr. No.	Phase	Indication	Type of RGN	Driver Action
1	Warning Level 1	 = High temperature lamp ON	Automatic RGN	Automatic – continue driving and lamp will go out
2	Warning Level 2	 = Service lamp blink +  = DPF lamp ON with every 5s buzzer	Manual RGN (Automatic RGN disable)	Start RGN via DPF switch (Please refer the procedure for DPF RGN)
3	Warning Level 3	 = Service lamp blink +  = DPF lamp ON with continuous buzzer	Manual RGN (Automatic RGN disable)	Start RGN via DPF switch (Please refer the procedure for DPF RGN)
4	Warning Level 4	 = Service lamp blink +  = DPF lamp blink with continuous buzzer	Service RGN (Automatic and manual RGN disabled)	Visit nearest ITL authorised dealer
5	DPF Clogged	 = Service lamp blink +  = DPF lamp blink with continuous buzzer	RGN Locked (All RGN disabled)	Visit nearest ITL authorised dealer

## 3. INSTRUMENTS AND CONTROLS

### 3.8.1 Procedure for manual DPF regeneration :

- Select an appropriate location to park the tractor (such as clean concrete or gravel, not grass or asphalt).
- Park the tractor away from anything that can burn, melt or explode.
- Park the tractor securely. Place the transmission in park, if provided, otherwise in neutral. Set wheel chocks at front and rear of at least one tire.
- Keep a fire extinguisher nearby.
- Check the exhaust system surfaces. Confirm that nothing is on or near the exhaust system surfaces (such as tools, rags, grease, or debris).
- Verify if the following conditions are met in the tractor:
  1. The brake pedal is released.
  2. The transmission is in neutral or park.
  3. The tractor speed is 0 MPH.
  4. The throttle pedal is released
  5. The A/C is turned off
- Initiate the manual regeneration by pressing and holding the DPF Regeneration Force switch a minimum of 6 seconds. This switch location varies by model (see left).
  1. Once the manual regeneration is initiated, the engine speed will increase, and turbo charger noise will increase.
  2. The High Exhaust System Temperature Lamp may illuminate during the manual regeneration as the exhaust temperatures increase.
  3. When the engine ECM detects that the after-treatment diesel particulate filter has been regenerated, the engine will automatically return to normal idle speed.
- Monitor the vehicle and surrounding area during the manual regeneration. If any unsafe condition occurs, shut off the engine immediately.
- Manual regeneration process may take up to 30 min to complete.



1. Do not use fuel and engine oil other than the specified /recommended type.
2. Do not perform regeneration when the vehicle is in an enclosed area , such as a garage, etc.
3. Do not drive the vehicle over or stop the vehicle near flammable materials
4. Do not idle or park the vehicle where flammable materials such as grasses, leaves , paper might burn easily.
5. Do not modified the vehicle exhaust system.
6. Check all hoses for cracks or damaged, which could cause leaks or possible failure. Replace damaged hoses

## 3. INSTRUMENTS AND CONTROLS

### 3.9 Battery

Battery is located under right side floor with Battery box (A).

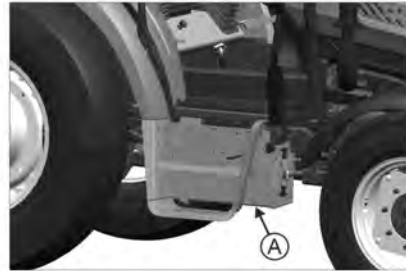

ITL000136

### 3.10 Seven Pin Rear Socket for Trailer

7-Pin socket is mounted on QRC plate to attach the trailer connections.

Details of connectors is as follows:

Pin No	Wire Colour	Function
1	Yellow	Turn LH
2	Blue	IGN +VE
3	White	Ground
4	Green	Turn RH
5	Brown	Position +VE
6	Red	Stop
7	Black	Position +VE

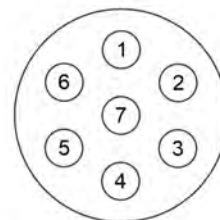

ITL000137

### 3.11 Three Pin Rear Socket

12V DC 3-Pin socket is mounted on QRC plate to use related electrical equipment.



ITL000138

## 3. INSTRUMENTS AND CONTROLS

### 3.12 Registration Plate (B)

A vehicle registration plate or number plate (A) is mounted at rear end of the tractor as shown in Figures.

#### NOTES :

1. Use registration plate as per regulations in your country.
2. Photograph shown may vary with registration plate fitted in your tractor.

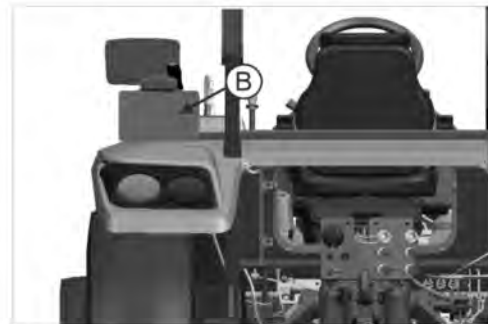

ITL000139

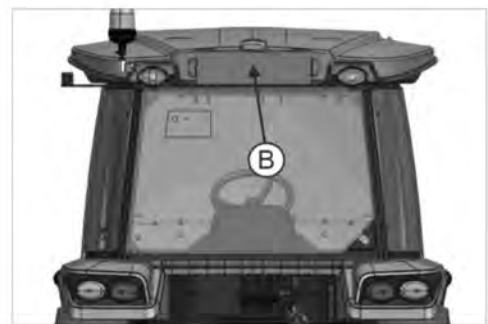

ITL000140

### 3.13 Tool Box (C)

Tool box (C) is mounted on back side of seat of the tractor near foot step.



ITL000141

### 3.14 USB Socket (D)

This point is used for charging of mobile phones etc.



ITL000142

## 3. INSTRUMENTS AND CONTROLS

### 3.15 Tractor Lights (Platform Tractor)

1- Head Lights

2- Front Parking Lights

3- Beacon Light

4- Registration Plate Light

5- Tail lamps

6- Indicator Light



Fig 3.5 (a)

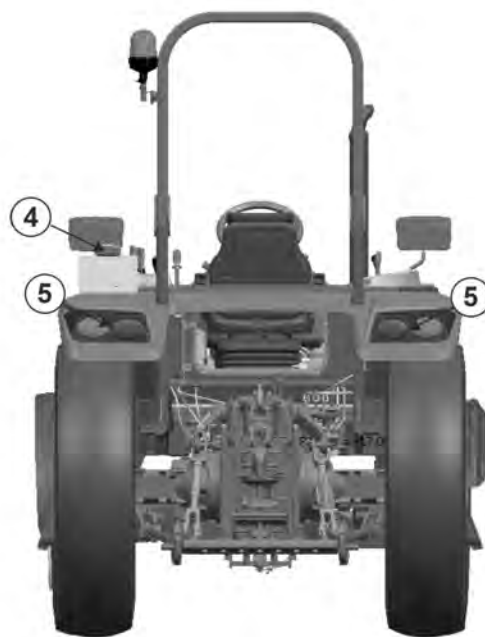

Fig 3.5 (b)

ITL000143

## 3. INSTRUMENTS AND CONTROLS

### 3.16 Tractor Lights (Cabin Tractor)

1– Head Lights

2– Front Work Lamp

3– Beacon Light

4– Registration Plate Light

5– Tail lamps

6– Indicator Light

7– Front Parking Light

8– Rear Work Lamp



Fig 3.5 (a)

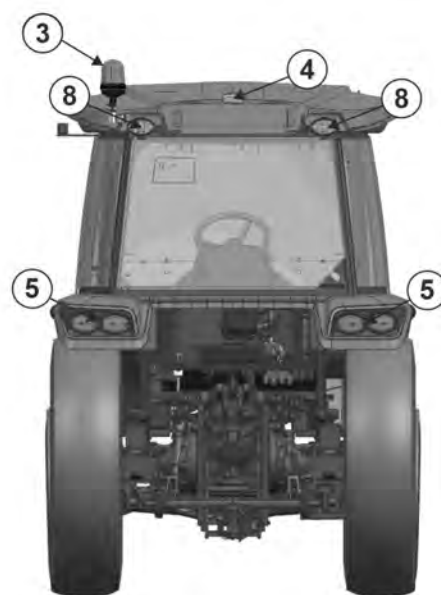

Fig 3.5 (b)

ITL000144

## 3. INSTRUMENTS AND CONTROLS

### 3.17 Tilt and Telescopic Steering

Operator can adjust steering wheel height (Up & Down) as well angle of steering column as per his comfort.

#### Adjusting Steering Wheel Height (See fig. 3-17 a)

- Unscrew steering wheel telescope release Ring (1, Fig. 3.17a)
- Pull up / push down steering wheel vertically.
- Tight the steering wheel telescope release Ring (1, Fig. 3.17a) to lock into position.



Fig 3.17 (a)

ITL000149

#### Tilting Steering Wheel (See fig. 3-9 b)

**Towards Operator :** Hold the lever (2, Fig. 3-17 b) in lifted position and pull steering column assembly towards operator side.

Select the inclined position and release lever (2, Fig. 3-17 b) for self locking.

**Away from Operator :** Hold lever (2, Fig.3-17b) in lifted position. Steering column will automatically move towards front side.

Release the lever (2, Fig.3-17b) to suitable position of steering column assembly.



Fig 3.17 (b)

ITL000150



**CAUTION :** Never adjust the steering wheel when the tractor in motion. If you determine that a readjustment is necessary, stop the tractor safely and adjust the steering wheel to the correct position.

### 3.18 Block Heater (Optional)

A block heater is used in cold climates to warm an engine prior to starting. Connector (A) for block heater provided under the LH platform.

500 Watts 220Volts A. C. Supply required to switch ON the Block Heater. It need to switch ON beyond -10 to -20 degree C. atmospheric temperature. The operator needs to disconnect the cable before driving

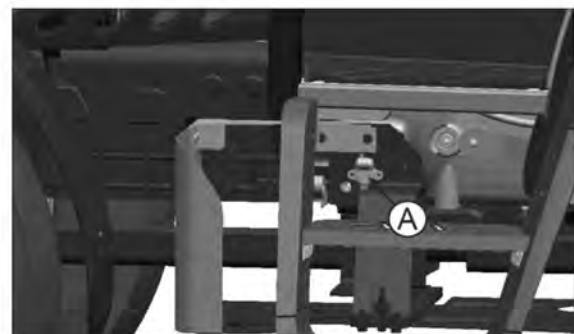

ITL000148



## 3. INSTRUMENTS AND CONTROLS

### 3.19 Driver's Seat

- Adjust to each operator's personal preference.
- For better result, make adjustments while seated in the operating position.

#### A- Travel Adjustment Lever

#### B- Weight Adjustment

#### C- Weight Indicator

#### D - Height Adjustment Knob

Following are available Seat adjustments:

**1. Travel Adjustment :** Lift up the Lever (A) provided at left side of seat. Slide the seat to forward or backward at required position. Release the lever to lock in the set position.

**2. Weight Adjustment :** Rotate the knob (B) according to weight of driver. Adjust seat for better suspension according to operator weight by rotation of knob (B). Clock wise rotation for hard suspension and anti clock wise rotation for soft suspension.

**3. Weight Indicator :** Weight indicator (C) indicates light weight and heavy weight. When rotate the knob (B) clockwise it will move to left side for light weight suspension.

**4. Suspension Height Adjustment :** Rotate the knob (D) for adjustment of desired seat height for comfortable driving.

**Seat Belt (E, Fig. 3-19 (c)) :** Automatic retracting type seat belt is provided. To fasten the seat belt pull the buckle tongue (E1) attach to the seat belt across you body and slide it into the buckle catch slot (E2) on opposite side until you hear a click.

To unfasten the seat belt press the release button on the buckle catch (E2).



Fig 3.19 (a)

ITL000145



Fig 3.19 (b)

ITL000146



Fig 3.19 (c)

ITL000147



**WARNING :** Wear your seat belt at all time during driving the tractor.

## 4. OPERATION

---

### 4.1 Operator Presence Control (OPC)

**4.1.1. Parking Brake OPC:** This tractor is equipped with an audible and visible alarm that alerts the operator when he leaves the driving position with the park brake not applied. This audible and visible alarm shall be activated after operator has been detected out of the driving position and the parking brake is not applied. The alarm shall be deactivated when the operator is detected to be present again in the driving position within this time period or when the parking brake is applied within this time period.

**4.1.2 Power take-off OPC:** When the operator leaves the driving position with PTO engaged and the vehicle is not in motion, the engine will shut off automatically which will shut off the drive of the power take-off shaft within 7 seconds. The automatic PTO shut off action shall not have negative effects on safety related functions (e.g. braking). A restart of the Power take-off shall only be possible with an intentional actuation by the operator.

### 4.2 Boarding The Tractor

Always board the tractor from left hand side where a footstep (A) is provided while taking care the other part of body must not foul with levers. This will provide ease to operator.



ITL000151

### 4.3 Leaving The Tractor

After stopping the tractor, leave the tractor from LH or RH side of tractor.

## 4. OPERATION

### 4.4 Opening The Bonnet

Insert the key (D) is provided with tractor into the key hole (B) provided on LHS corner and push gentle till click noise is heard.

Slot (C) provided for lifting the bonnet.

The bonnet will automatically lift up to the preset height with the assistance of gas springs.

To close the bonnet gently lower the bonnet down then press it until lock is engaged.

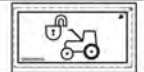
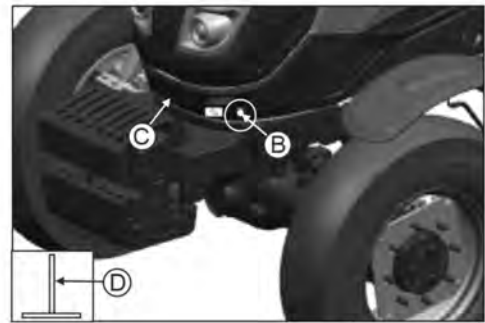

ITL000152

### 4.5 Engine

#### Starting the Engine



**WARNING:** Make sure that the starting system allows the engine to start only when all gear & PTO levers are in neutral position. If this fails to occur, have the tractor repaired by your dealer or authorised service center.



**WARNING:** When the engine is running, keep as a safe distance from the radiator fan.

A- Check that, the gearshift lever and the range selector lever are in neutral.



**WARNING:** To prevent accidents, never allow anyone to sit on the mudguards or on any other part of the tractor or implement.

B- Tractor is equipped with clutch safety switch, always press clutch pedal fully before starting.

### 4.6 Turbo Engine

Turn the ignition key to the "ON" position. Then turn the key to the "START" position. Release the key as soon as the engine fires and quickly set the accelerator lever to the idling speed.

Accelerate to a 1000 -1200 RPM without increasing further speed until the engine has reached to the normal operating temperature.

Allow the engine to run at idle rpm for 1-2 minutes to allow the turbo charger to be lubricated.

## 4. OPERATION

### 4.7 Cold Weather Starting, Temperature Below 0° C (32° F)

**IMPORTANT** : When outdoor temperature drop to around or below 0 C (32 F), check the cooling system and if necessary add the recommended antifreeze.

**IMPORTANT** : Do not inject fluids (ether) to make the engine to start in cold weather. The tractor is equipped with a cold start device.

#### Procedure as follows :

- Perform operation A& B as instructed above.
- Turn the ignition key to the pre-heat position and keep it there for 20 second, then turn the ignition key to the " START" position. If the engine fails to start within 15 seconds, return the key to the pre-heating position.
- Wait a further 10 seconds and then turn the ignition key to the "START" position again.

#### NOTE:

- If the engine fails to start after or three attempt and smoke can be seen coming out of the exhaust, repeat the starting procedure without the thermostarter pre heating phase.

- Do not keep the key turned to the start position for more than 15 seconds at a time.
- Wait at last 1 minute between one attempt at starting and another.

If the engine does not start regularly and easily, do not continue as for you may run down the battery. Bleed any air that may have accumulated in the fuel system and, if the problem persists, check that :

- The fuel filters are not blocked.
- The battery and thermostarter are efficient.

### 4.8 Running in

It is essential to take following precautions during the first 50 hour of running-in:

1. It is recommended by the manufacturer, to run tractor for first 50 hour at part/marginal load condition of better working life & good productivity. Tractor with Green Engine, New drive line & axle Assembly endorse Initial wear-tear during this period.

2. Engage low gear & prefer moderate load.

3. When running-in, check regularly that all Screws & Nut Bolts are tight

4. To ensure prolong clutch life, operate clutch smoothly and carefully.

**NOTE** :For longer clutch life, avoid clutch riding.

### 4.9 Marching the Tractor



Before moving off, make sure you are perfectly familiar with the brakes, transmission, PTO, differential lock and engine shutoff.

#### After starting the engine :

1. Fully press the clutch pedal, select the gear required and then select the speed range.
3. Accelerate the engine slightly and gradually release the gearshift clutch pedal.

## 4. OPERATION



**WARNING** : Make sure that the lever is set for the direction required.

2. Release the parking brake.



**WARNING** : Look out of bystanders, especially when moving in reverse direction.

4.

Move your foot completely off the clutch pedal and slowly accelerate until you have reached the speed you need.



Do not keep your foot on the gearshift clutch pedal when driving and remember to check and adjust the clutch to prolong its life and avoid sudden damage to it.



Your tractor is equipped with a mechanical reverse shuttle, always bring the tractor to a complete standstill before changing direction.

### 4.10 Acceleration Control

#### Hand Throttle Lever (A)

Hand throttle lever (A) mounted on RH side fender is used in the field application. To increase the speed of engine, move outward the lever and to decrease, pull inward the lever.

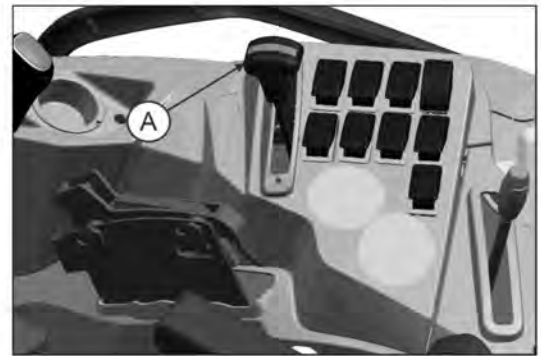

ITL000153

#### Foot Accelerator (B)

While using foot accelerator (B), keep the hand throttle in idle position moreover while using hand throttle the foot accelerator can be used to accelerate above the speed set by hand throttle.

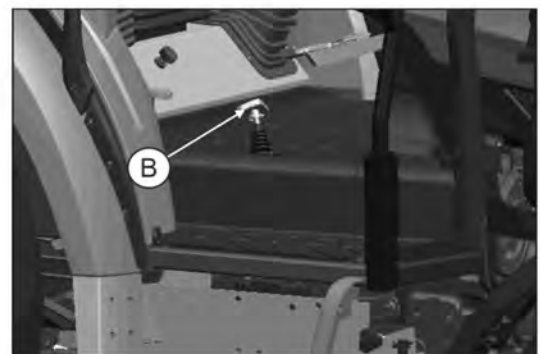

ITL000154

## 4. OPERATION

### 4.11 Stopping the Tractor

- Reduce the engine speed.
- Press the clutch pedal to disengage drive.
- Once the tractor has come to stop, move the gear lever and speed range lever to neutral before releasing the gearshift clutch pedal.
- Use both pedal brakes to stop the tractor and then apply the parking brakes.

### 4.12 Turning off the Engine

- Accelerate the engine to rated RPM for 3-5 seconds (for Turbo engines).
- Turn the hand throttle lever to the "idling" position.
- Stop the engine by turning the ignition key to the OFF position.

### 4.13 Exhaust ATS

Diesel oxidation catalyst (A) and diesel particulate filter (B) are provide to control the emission level.

**A — Diesel oxidation catalyst**

**B — Diesel particulate filter**



ITL000155

### 4.14 Clutch Pedal

Pedal released = Drive engaged.

Pedal pressed = Drive disengaged.

Select lower gear as per load condition and don't over ride the clutch for acceleration.



ITL000156



Never keep your foot resting on the clutch pedal when driving.



Never coast down slopes with the gear lever in neutral/clutch pressed when in gear.

## 4. OPERATION

### 4.15 Gear Change Levers

#### Speed Range Levers

There are three lever are provided on tractor to drive as per required speed ,range and direction.

#### Gear Speed Lever (D)

- Four speed selector

#### Range Selector Lever (E)

- High
- Medium
- Low

#### Shuttle Lever (F)

- Forward
- Reverse

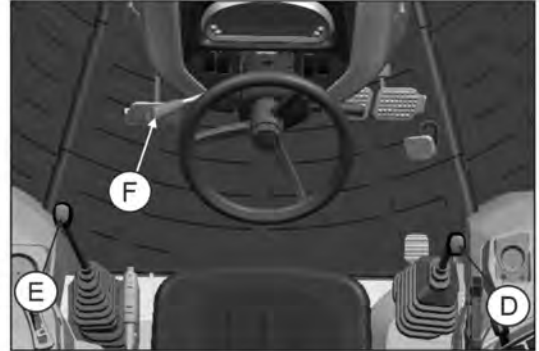

ITL000157

### 4.16 Gear Speed Lever

The lever has four different positions. All four gears are fully synchronized.

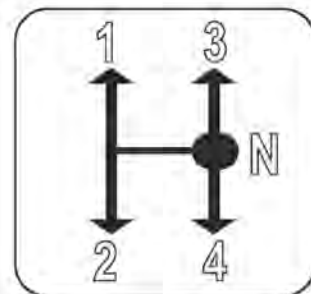

ITL000158

### 4.17 Range selector lever

The speed range selector lever has three possible positions corresponding to the low, medium and high speed ranges. Each range is identified by a symbol on the knob of the lever.

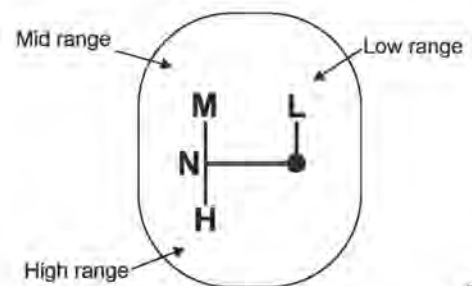

ITL000159

## 4. OPERATION

### 4.18 Forward/Reverse Lever

The lever has two positions viz. forward and back for moving the tractor in forward as well as reverse without gear shifting position.

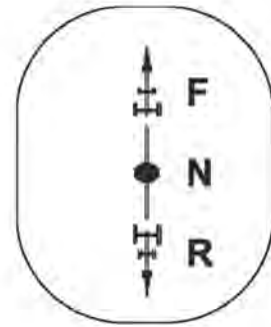

ITL000160

### 4.19 PTO Lever

The lever has three positions viz. ground PTO, neutral position and live PTO position.

**NOTE :** To change from one speed range to another, press the clutch pedal, and bring the tractor to a complete standstill before

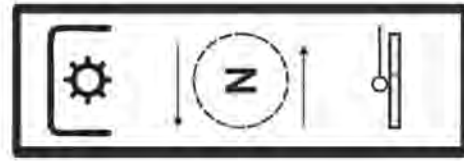

ITL000161



# 4. OPERATION

## 4.20 Power Take-Off

Tractor is equipped with standard PTO that complies with International regulations. PTO output shaft (A) is Installed at the rear of transmission housing.

### PTO Shaft can be driven in either of two modes

#### 1. Live PTO

It is directly driven by engine and its operation is independent of tractor movement i.e. Either stationery or moving.

Live PTO engages with PTO lever (B) in Backward position.

Option of 540 PTO RPM / 540 E can be selected with the help of selector lever provided at rear end of differential housing.

Live PTO can be disengage by pulling up independent PTO clutch lever.

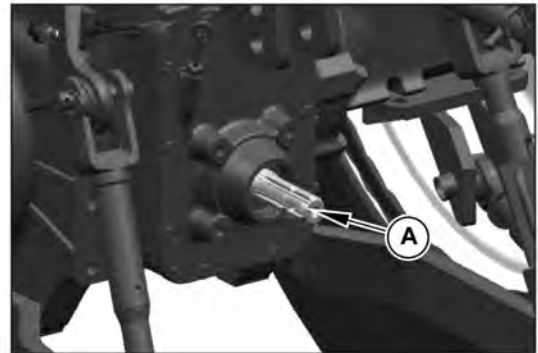

ITL000162

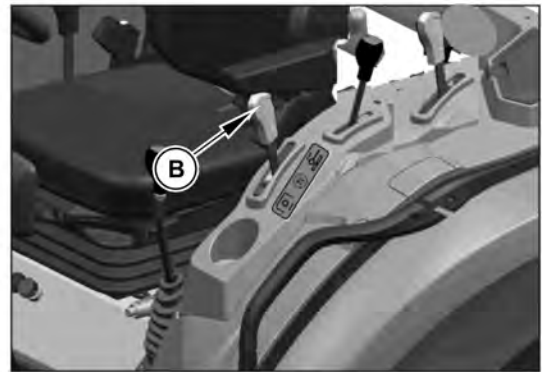

ITL000163

#### 2. Ground PTO

Ground PTO with variable PTO speeds w.r.t. gear can be utilised irrespective of tractor movement (Forward, Reverse or Stationery).

Engine power flows through Gear box / Rear Axle to PTO shaft.

PTO lever will be in Forward position.

Forward / Reverse gear Engaged (Tractor Movement).

Independent PTO clutch lever will be in normal Engaged (Down) position.

Symbol	→ GROUND PTO	N	← LIVE PTO
PTO Drive Ground / Live PTO	LIVE PTO	NETURAL	GROUND PTO
LEVER POSITION	FORWARD ←	CENTRE	BACKWARD →

ITL000164

### While Tractor is Stationery

Forward / Reverse gear Engaged, Parking brake Engaged.

Shuttle lever in Neutral position.

PTO lever in Forward position.

Ground PTO can be disengaged either by pulling up independent PTO clutch or pressing clutch pedal.

## 4. OPERATION

### 4.21 PTO Speed Selection (A)

PTO out put has two speeds i.e. 540 and 540E which can be selected through PTO speed selection lever. Speed must be changed with PTO disengaged.

PTO SPEED SELECTION	FORWARD	CENTER	BACKWARD
LIVE PTO 540 / 540E	540	NEUTRAL	540E
Engine RPM	1904		1646
GROUND PTO	@ REAR AXLE REVOLUTIONS		



ITL000165

#### Economy PTO

A PTO speed of 540 RPM can be obtained for implements that do not require maximum power, such as fertilizer spreaders, sprayers, etc by using the PTO at 540E RPM and decelerating to ~1650 RPM. The PTO economy mode has a number of advantages including a reduction in fuel consumption, noise and vibrations.



Never exceed 1904 or 1938 RPM (as per engine rated RPM) of engine when using 540E to avoid damage to the drive line itself, to the connected implement and persons.

# 4. OPERATION

## 4.22 Independent PTO Lever (B)

Normal position (Forward) - PTO engaged.

Pulled Backward - PTO Disengaged.

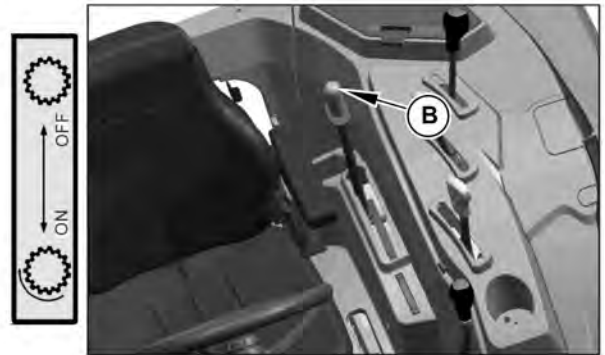

ITL000166

PTO FLOW CHART				
LEVER POSITION & PTO DRIVLINE REVOLUTIONS				
PTO MODE	GEAR SPEED LEVER	PTO ENGAGEMENT LEVER	INDEPENDENT CLUTCH LEVER	PTO SPEED
LIVE PTO	Neutral /Gear	Forward	Engage (Forward)	Forward 540 Backward 540E
	Neutral/Gear	Backward	Disengage (Normal Position) (Backward)	PTO Stop
GROUND PTO	Engage	Backward	Engage (Forward)	At rear axle revolution

**WARNING:** PTO shafts and implements operated by means of the PTO can be extremely dangerous. It is therefore advisable to comply with the following important instructions:

**WARNING:** When PTO is running always use Protective Shield and when PTO is not operational protect PTO splines with PTO Cap (A).

These parts protect persons from injuries and the shaft splines from damage.

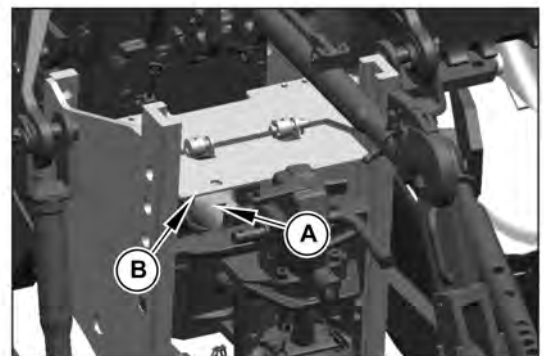

ITL000167

## 4. OPERATION



**WARNING:** Before connecting adjusting or working on implements operated by the PTO, disengage the PTO, stop the engine, remove the key from the dashboard and engage the parking brake. Do not work under raised implements.



**WARNING:** Check to make sure that all implements operated by the PTO are fitted with the correct protections, are in a good condition and comply with the provisions established by law



**WARNING:** Before driving an implement through the PTO, ALWAYS make sure that all bystanders are well away from the tractor.



**WARNING:** Fix the draw bar in the central position when using implements that are driven by the PTO of the tractor.



**WARNING:** When using the PTO drive with a stationary tractor, ALWAYS make sure that the gears are in neutral and that the parking brake is applied.



**WARNING:** Before starting up any PTO driven implement hitched to the three-point linkage, lift the implement to its full height using position control and check that at least 1/4 of the total length of the telescopic section of the drive shaft is engaged.

**IMPORTANT :** When using the synchronized PTO and if you are forced to reverse once or several times, remember that the driveline inverts its spinning direction. Thus with certain implement, it is advisable to disengage the PTO when reversing in order to avoid major damage.



**WARNING :** Only use PTO at 540 RPM (or 540 ECO) to drive implement designed for such respective rotation speeds.

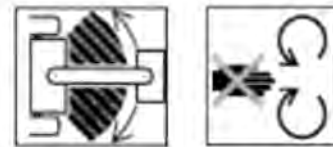

ITL000168

## 4. OPERATION

### 4.23 Service Brake (A)

The main brakes are operated by means of two pedals one for each rear wheel. Braking on one side assists steering in tight maneuvers. By locking rear wheel on the inside of curve, you can virtually turn the tractor around on its own axis. For simultaneous braking during normal use and for on road use, simply lock the two pedals together with the brake pedal latch pin (B).

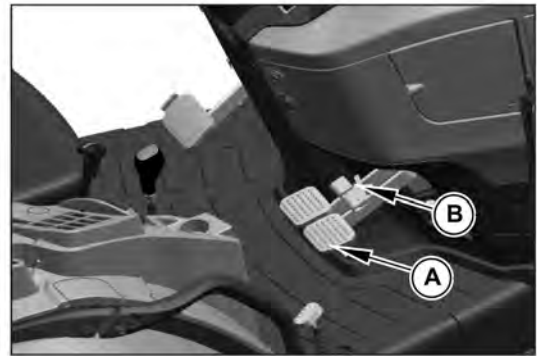

ITL000169

 **WARNING:** Always keep the brake pedals coupled for on-road driving to ensure simultaneous braking on both rear wheels. Never use the brakes independently when driving on public roads.

 **WARNING:** If you ever notice the brakes becoming less effective, identify the cause immediately and repair. When working on slopes avoid using the brakes as much as possible and select a lower gear in order to use engine braking.

### 4.24 Parking Brake (C)

The Parking brake (C) is engaged by the parking brake lever which acts on the brake discs by means of a mechanical control.

#### Parking brake engagement:

- Pull the parking brake lever upward to operate the parking Brake.

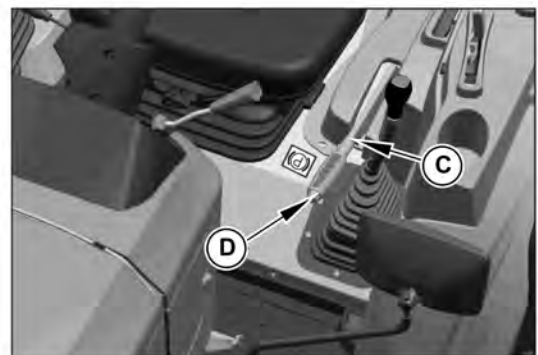

ITL000170

#### Parking brake release:

Press the button (D), push the parking brake lever downward and release the button.

## 4. OPERATION



**WARNING:** Always engage the hand brake when the tractor is used for work at a standstill, even if only for brief periods of time.

**IMPORTANT:** Driving the tractor with the parking brake partially engaged will cause damage to internal transmission components. Make sure the brake is fully off.

### 4.25 Dual Air Trailer Brake (Optional feature)

The air brake is available as dual-line system or as combined single-line and dual-line system. Trailers with single-line brakes may be connected at connection (A).

Trailers with dual-line brakes may be connected at connections (B) and (C).

Ensure that the connections are clean before joining the compressed air hoses. Seal the connections with the dust caps whenever the hoses are disconnected.

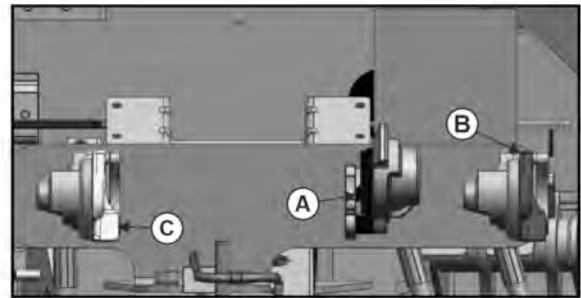

ITL000171



**CAUTION :** The single-line trailer brake may be used at speeds up to 25 km/h only. When travelling with the tractor, keep within the legal speed limit.

**IMPORTANT:** With a trailer connected, do not drive away unless the air pressure gauge is indicating at least 810 kPa (8.1 bar or 117 PSI).

To prevent undue wear on the brakes, observe the following points:

- Make sure that the pressure hoses are connected.
- When driving downhill, select the same gear you would for driving uphill.
- Check the air brake on the trailer regularly to make sure that it is functioning correctly.

**A – Yellow colored Palm coupling (single-line brake, if equipped)**

**B – Black colored Palm coupling (dual-line brake, supply)**

**C – Red Color Palm coupling (dual-line brake)**

**NOTE:** Loss of pressure may cause the brake to become less effective. Operate the trailer in accordance with the manufacturer's instructions.



**CAUTION :** When operating with a trailer: 1. Remember to set the manually-operated brake valve on the trailer's air brake system (if equipped) in accordance with the weight of the trailer's load. 2. Drain the water from the compressed air tank regularly ("Service - Daily or as required")

## 4. OPERATION

### 4.26 Hydraulic Trailer Brake (HTB) (Optional feature)

Hydraulic trailer brake valve is provided, which is connected directly on main hydraulic line. The valve is actuated with movement of brake lug. i.e. when tractor service brake is actuated, the hydraulic brake valve is also pressed, which results in hydraulic oil flow towards trailer side, resulting in braking of trailer.

If adjustment is required in actuation, the push pull wire and the valve position can be adjusted accordingly, for actuation.



Never exceed a speed of 25 km/h (>15 mph) when traveling with hydraulically braked trailers.

**IMPORTANT:** To prevent undue wear on the brakes, observe the following points:

- Make sure the pressure hose is connected.
- Select the same gear for both downhill and uphill driving.
- Check the hydraulic trailer brake regularly to make sure that it is functioning correctly.

**NOTE:** The tractor parking brake has no effect on the hydraulic trailer brake. Operate the trailer in accordance with the manufacturer's instructions. This is particularly important when operating the parking brake of the trailer



High Pressure oil is being supply through the QRC Coupler (A).

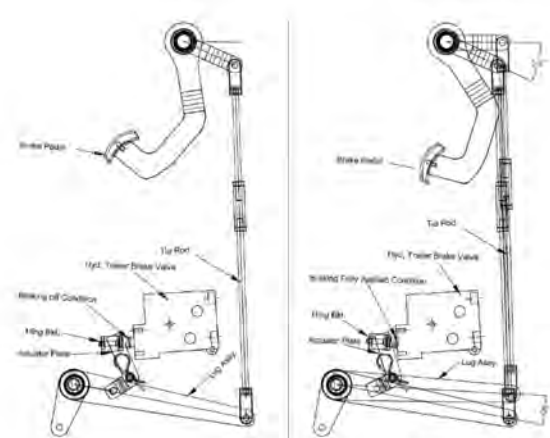

Braking off Condition

Brakes fully applied condition

ITL000172



ITL000173

## 4. OPERATION

### 4.27 Differential Lock

The rear axle differential is equipped with a locking device to engage when one of the rear wheels slips owing to lack of grip. To lock the differential, slow the tractor down and fully press the pedal .

**NOTE:** For the best results, engage the differential lock before the wheels are likely to slip. Do not engage the differential lock while one of the wheels is actually slipping. Do not lock the differential without having first depressed the clutch pedal.

The differential must remain locked until the driving wheels regain their grip. To disengage the lock, just remove your foot from the pedal. If the differential fails to release, sharply brake on the wheels. Brake the wheel that is out of the furrow during ploughing work.

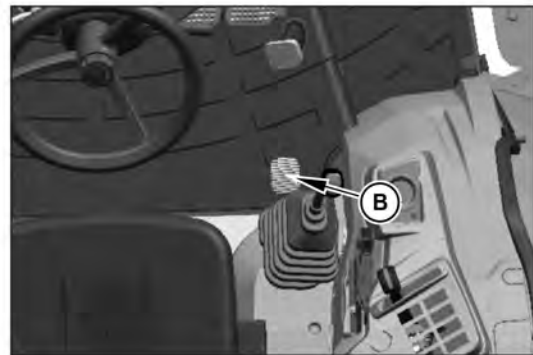

ITL000174



Operate the Differential Lock Pedal 2-3 times once in a month in stationary condition

#### B — Differential Lock



Never use the differential lock when driving the tractor on public roads.



Do not apply differential lock while tractor speed is more than 6 kmph [3.73 mph] on turning.

### 4.28 Ground Speeds

Following listed gear speeds are in **Kmph** at 2000 rated engine rpm with 13.6x28 Rear tyres. To convert Kmph into mph, multiply with 0.625.

	Range	Gear	Speed (Kmph)
FORWARD GEAR	Low	1	1.33
		2	1.97
		3	2.89
		4	3.97
	Medium	1	3.65
		2	5.41
		3	7.93
		4	10.90
	High	1	10.02
		2	14.84
		3	21.76
		4	29.90



# 4. OPERATION

	Range	Gear	Speed (Kmph)
REVERSE GEAR	Low	1	1.2
		2	1.78
		3	2.61
		4	3.59
	Medium	1	3.29
		2	4.88
		3	7.15
		4	9.84
	High	1	9.04
		2	13.40
		3	19.64
		4	26.99

**Note:** Above speeds can vary within  $\pm 5\%$  according to tyre pressure & loading conditions.

## 4.29 Adjusting Rear Wheel Track

The rear track width can be adjustable by changing the position of the rim fixing points or central wheel discs, as shown in the table below.

Torque the nuts and bolts that fix the rim to the disc to 250 Nm and those (B) that fix the disc to the wheel hub to 280 Nm. Always check tyre pressure.

Track widths can be obtained with some tyre types

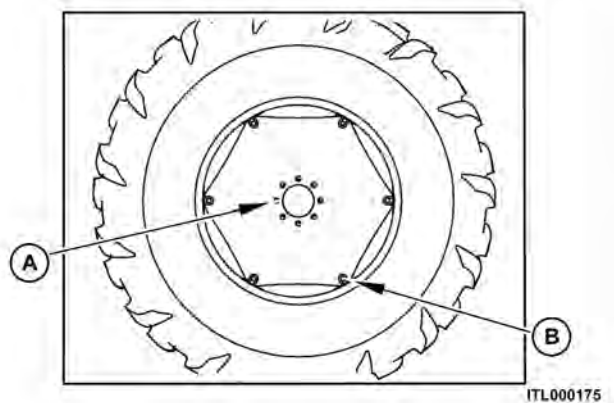

ITL000175



**WARNING :** When jacking up the tractor, pay attention that its weight is correctly distributed and securely wedge the wheels on the ground tighten all nuts and bolts to the required torque.



**WARNING :** Rear wheels are very heavy. Always use a hoist or other suitable lifting equipment to handle, "mount and dismount wheels.

### Rear Tracks Disc Pointing:

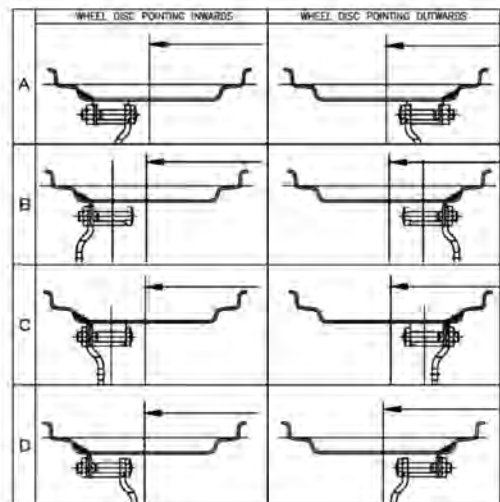

ITL000176

## 4. OPERATION

### 4.30 Wheels and Tyres

Regularly check that the front and rear wheel nuts are fully tightened.

Tyre pressure must be checked and adjusted before using the tractor.

**NOTE :** The pressure should be adjusted afterwards by the user according to values given in the tables of tire manufacturers and to the use anticipated for the tractor.

If these simple rules are carefully followed, they will ensure maximum working life for your tyres.

If you notice any cuts in the tread or side walls, have them vulcanized immediately to avoid further damage to the tyres.

Drive slowly on roads if the pressure in the tyres has been reduced for use on soft earth.

**NOTE :** If the tractor is not going to be used for a long period of time, support it on raised blocks to remove the load from the tyres.

**NOTE :** Avoid parking the tractor on floors which are covered with oil or diesel fuel. Also avoid parking the tractor where the tyres are permanently exposed to direct sunlight, especially if the tractor is not going to be used for some time.



**WARNING :** When jacking up the tractor, pay attention that its weight is correctly distributed and securely wedge the wheels on the ground. Tighten all nuts and bolts to the required torque.



**WARNING :** Always use a hoist or other suitable lifting equipment to handle, mount and dismount wheels.

**TYRE SIZE & RECOMMENDED AIR PRESSURE AS PER APPLICATION**

TYRE SPECIFICATION			Load Carrying Capacity /Tyre (Kg)	RECOMMENDED AIR PRESSURE (PSI)	
				FOR FIELD APPLICATION	FOR HAULAGE APPLICATION
FRONT	BIAS	9.50x20	1040 Kg @ 250 kPa	24 ~ 26	28
FRONT	BIAS	13.6x28	1700 Kg @ 160 kPa	14	20

**Note:** Tyre Pressure in field may vary according to Load on rear axle.

## 4. OPERATION

### 4.31 Ballasting the Front Axle

If heavy implement that might destabilize that tractor are hitched to the lift, cast iron plates can be added to the front end to counterbalance their weight.

The plates have handles so that they can be mounted and demounted more easily.

They should be applied to the support and fixed with the relative rods.

#### IMPORTANT :

- Do not ballast the tractor over its rated carrying weight.
- When using the tractor for light work, transport and on road towing, remove the ballast to avoid unnecessary strain on the mechanical components.
- With semi-mounted and fully mounted implement (which inevitably increase the load on the rear axle of the tractor), Ballast must only be used when strictly necessary. There is no point in increase grip beyond the level necessary for efficient work as this will reduce tyre life.
- Carefully check the tyre inflation pressure since this will make the tyre last longer and ensure a wear more evenly on regular use.

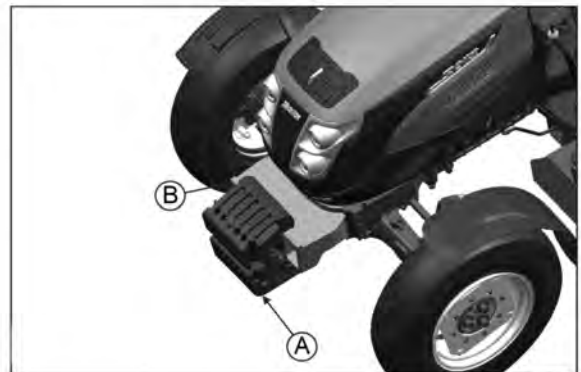

ITL000177

BALLAST MASS (Front)	
Cast Iron Weight (A)	CI Block (B)
*6 Numbers of 32kg. each can be added as maximum ballast	Cast iron, Block 72kg.

The softer the soil, the lower tyre inflation must be, while the tyre should be inflated to a greater extent as the soil becomes more compact.

**WARNING :** Manual lifting of the ballasting is a potentially dangerous operation.

\*Note: Ballast Masses are not a standard fitment to tractor.

### 4.32 Adjusting The Maximum Steering Angle for 4WD Axle

The maximum steering angle of the 4WD front axle can be varied depending on the type of tyre mounted and the way the tractor is used.

The angle is changed by adjusting the stop screw (C) on the final drive of the axle and locking check nut (D).

This adjustment is very useful when adopting minimum track since it prevents the wheels from interfering with the engine housing.

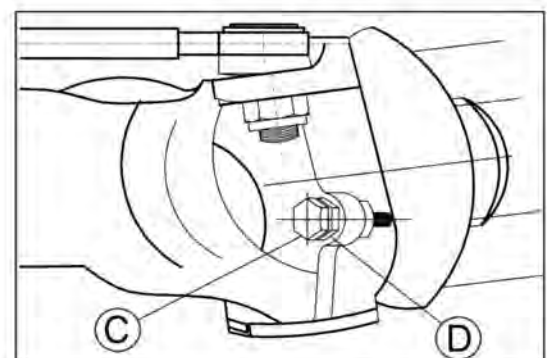

ITL000178

## 4. OPERATION

### 4.33 Ballasting with water for Rear wheels

Add weight to rear wheels if needed to improve traction or for stability. The amount of rear ballast should be removed when it is not needed.

The weight should be added to the tractor in the form of liquid ballast, rear weight or a combination of both.

#### Liquid Ballast in Rear Tyres

Water and calcium chloride solution provides safe economical ballast. Used properly, it will not damage tires, tubes or rims. The addition of calcium chloride is recommended to prevent the water from freezing. Use of the method of weighting the wheels has the full approval of the tyre companies. See your tyre dealer for this service.

#### How to ballast (Liquid)

- Jack up the rear wheels.
- Rotate the wheel assembly valve on top and remove the valve and let the air move out of the tyre.
- Start filling water with the help of special adaptor.
- Filling tube nozzle should be at 12 O' Clock position.
- Remove the water hose/special adaptor when tube is filled in with water.
- Rotate the tyre to bring tube nozzle position to 11 O' Clock & remove the valve. Let the excess water drain out till it stops flowing.
- Bring tyre to 12 O' clock position.
- Put the air valve on the tube nozzle.
- Fill in the air upto normal inflation pressure. Thumb rule 75% water at 11 O' Clock position, 25% Air.

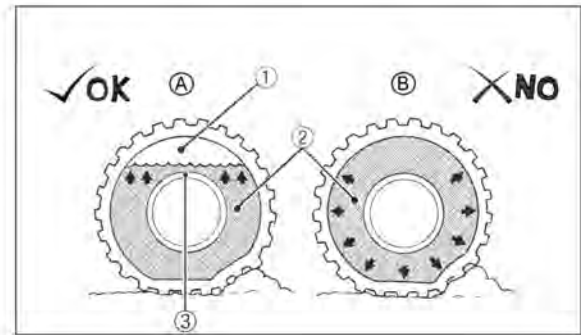

ITL000179

(1) Air (A) correct - 75 % Air compresses like a cushion

(2) Water (B) Incorrect - 100 % Full water can not be compressed

(3) Valve Stem

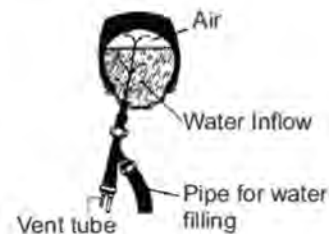

ITL000180

## 4. OPERATION

### Ballasting with C.I. Weights for Rear Wheels (Optional)

Additional cast iron weight are fitted on rear tyre before adding ballast confirm with dealer if it is required or not.



During fitting / removing CI take care following :-

- Bolt thread damaging.
- Hand / safety of persons nearby.

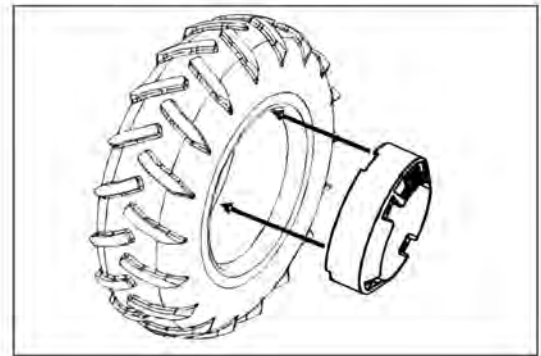

ITL000181

### Lower Links

#### Lower links with Class 2 fixed ball ends Adjusting the RH and LH vertical lift rods.

The two vertical lift rods can be adjusted by means of adjuster arms in order to alter the lateral angle of the implements.

The latter position must be used for : implements that require a certain freedom of movement (cultivators, spaders, harrows, ploughs).

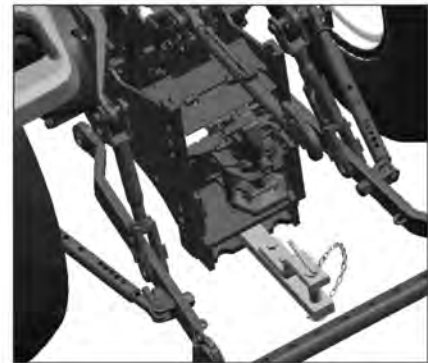

ITL000182



**WARNING** : ALWAYS use great caution when adjusting or using the three-point linkage.

### 4.34 Hitching Implements

1. Lower the three-point linkage.
2. Adjust the lateral stabilizer let the lower links swing freely.
3. Reverse the tractor on the implement.
4. Raise the three-point linkage until the hooks on the lower links fasten on to the ball ends on the implement crossbar and secure them with safety clips.
5. Adjust the stabilizers to give the right amount of lateral swing for the implement.
6. Hitch up and adjust the top link.

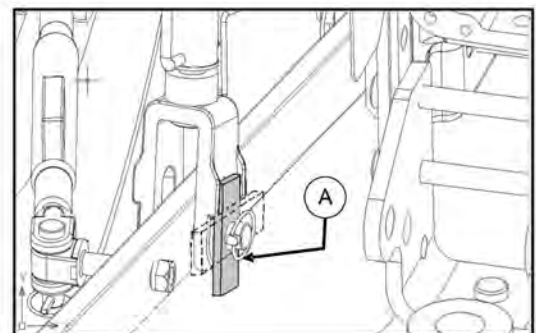

ITL000183

## 4. OPERATION

### 4.35 Unhitching Implements

1. Lower the implement to the ground.
2. Adjust the stabilizers to give the correct freedom of movement to the lower links.
3. Remove the safety clips and unhitch the Implement's crossbar from the hooks on the lower links.

The following are important warnings for the operation and adjustment of implements on the three point linkage.

Use for adjusting the float position use in vertical position if certain degree of freedom is required for trail type implements. Use horizontal adjustment for locking the lower links and for adequate sensing. Also use the float mode while hitching the implements for ease in hitching.



**WARNING** : ALWAYS stop the engine before attempting to adjust the three-point linkage or any implement hitched to it.



**WARNING** : ALWAYS select position control mode when transporting mounted implements on the three-point linkage. Lock the implement into transport position.



**WARNING** : Before getting off the tractor, always lower to the ground any implement that is mounted on the three point linkage.



**WARNING:** Never work underneath an implement held up only by the hydraulic power lift and three-point linkage. Support the implement for safety and stop the tractor engine.



**WARNING:** Stay away from the area of three point linkage while attachment / detachment of implements.

**NOTE:** Maximum Lift Capacity of Three Point Linkage is 2500 Kg - Standard / 3000Kg- Optional.

**NOTE:** Maximum allowed vertical load on Drawbar is 2039 Kg and on Clevis Hitch is 2039 Kg.

### 4.36 Quick Attach Three Point Linkage and Ladder Hitch with Clevis (Optional Feature)

#### Three Point Linkage Area:

- Attachment can be quickly and easily connected with the help of quick attach three point linkage.
- Cat-II heavy duty self locking type on lower links (B).
- Cat-II heavy duty self locking type Top links (A).

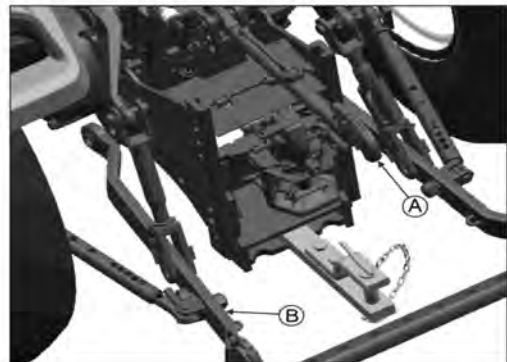

ITL000184

## 4. OPERATION

### Hitch Area:

- Rotating trailer hitch (clevis) ladder type semi automatic / automatic .
- Swinging draw bar with pin.
- Swinging draw bar Ladder type .



**WARNING:** Stay away from the area of three point linkage while attachment / detachment of implements.

### 4.37 Quick-Coupling (Hook-Type) Draft Links

These draft links are intended for Category II implement balls.

**IMPORTANT:** The balls must be the correct size

#### How to use the coupler hooks

The couplers are operated by means of lever (A), which can be actuated either by hand or by a control cable.

**IMPORTANT:** Make certain that the coupler hooks are locked:

Lever must be in contact with the coupler hook, there must be no play noticeable at ball and pin must enclose the ball.

If coupler hooks have a control cable, pay attention to the cable routing after the implement has been attached. If the cable droops excessively or gets tangled in undergrowth or branches, the hooks may be opened by accident.

**NOTE:** The coupler hooks can be locked in their "open" position.

To close the coupler hook again, first pull the lever up at an oblique angle.

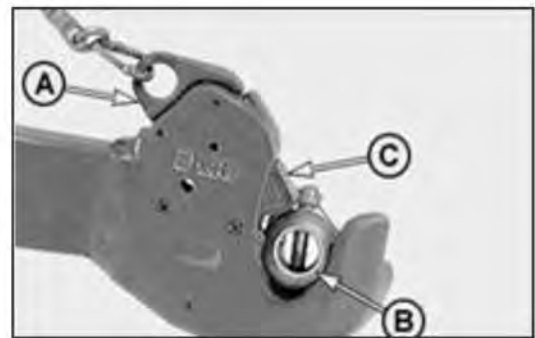

ITL000185

**A - Lever**

**B - Ball**

**C - Pin**

## 4. OPERATION

### Quick Attach linkage on Lifting device

#### Step A:

Roughly align the tractor with the equipment to be attached.

Adjust the distance of lower lifting arms and lateral stabilizers to accommodate the width of add-on being connected.

Lower the bottom gripping hooks below the equipment connectors and bring them closer until the hooks are beneath the pins.

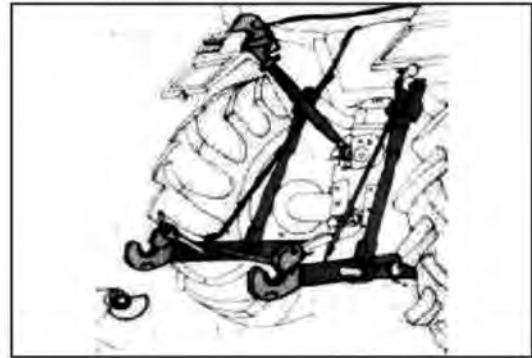

ITL000186

#### Step B:

Raise the lower lifting arms until the two pins automatically couple.

Joining is aided by conical profile or balls of conical profile that are commonly mounted on pins of the equipment.

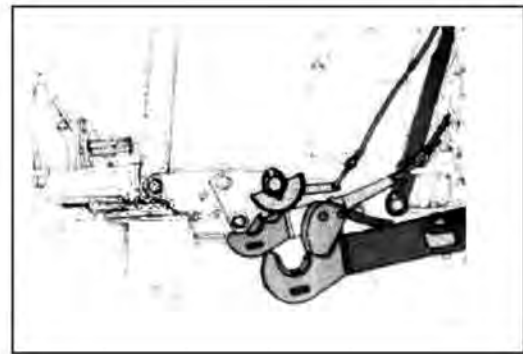

ITL000187

#### Step C :

Adjust the length of the upper link accordingly so that the hook is located over the pin of the equipment.

Lower the upper link until the hook automatically couples with the pin of the equipment.

Check once again to see if the gripping hooks are securely locked.



ITL000188



## 4. OPERATION

### Step D :

Connect and join shafts.

The equipment is now securely coupled and ready to be used.

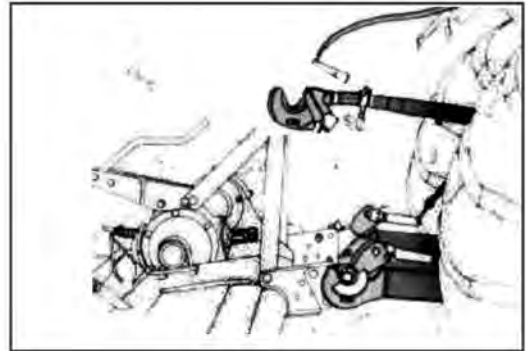

ITL000189

### Step E:

To decouple the equipment when finished working, lower the equipment to the ground, decouple the hook of the upper link using the control handle and secure the upper link to the appropriate bracket on the tractor. The equipment is now securely coupled and ready to be used.

De couple the two lower links using the control cable and then lower the bottom lifting arm.

Turn off the PTO (if in use) and detach any jointed shaft.

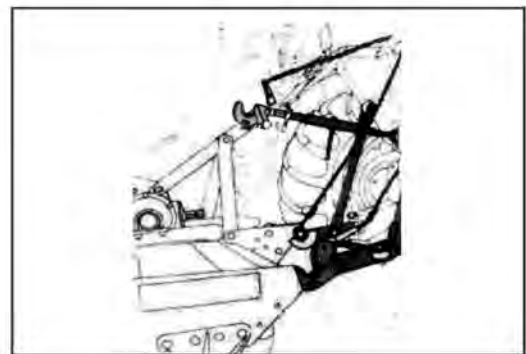

ITL000190

### Step F:

For particularly different operating conditions, prevent the bottom hooks from accidentally opening.

To do so, close the hook lock by inserting a bolt through the security hole and securing it with a nut.

Lock the clamping sleeve.

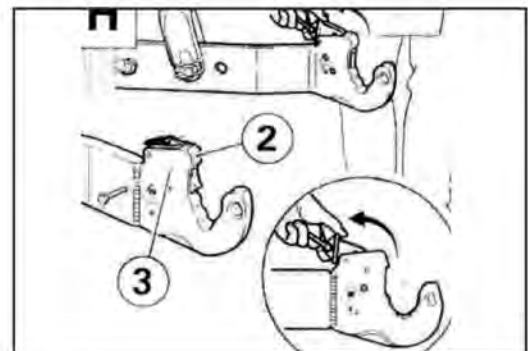

ITL000191

## 4. OPERATION

### 4.38 Three-point Linkage

These tractors are equipped with a class 2 three point linkage provided with fixed ball ends. To ensure correct tractor operation, check that the dimensions and weight of each implement correspond to the three point linkage and power lift specifications.

#### Components of three-point linkage

Standard three point linkage with fixed ball ends.

- A. Adjust top link
- B. RH adjustable lift rod
- C. Lateral stabilizers
- D. Lower links
- E. LH vertical lift rod

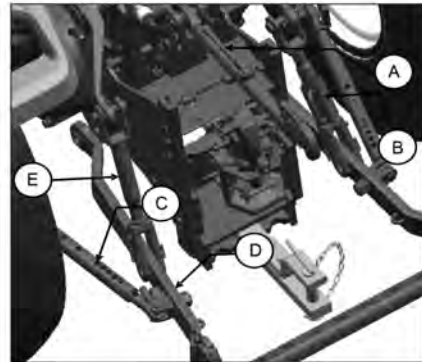

ITL000192

#### Adjustable Top Link

1. The adjustable top link is supported by a bracket with three fixing holes. The correct hole to use depends on the height of the implement.
2. Adjust the length of the top link to vary the attachment angle of the implement in relation to the ground.

3. Shorten the top link to increase the angle of attachment.
4. Lengthen it to reduce the angle of attachment.

#### Adjustable Rh Lift Rod or Leveling Rod

The right hand lift rod can be adjusted mechanically or hydraulically, depending on the lifting, to make the lower links level and lined up with each other.

This will depend on the type of implement being used and the work to be done.

#### Mechanical Adjustment

Shorten the RH vertical lift rod by turning it clockwise. Lengthen the RH vertical lift rod by turning it anti clockwise.

The lateral stabilizers can be set to reduce lateral movement of the lower links if the threepoint linkage.

- With ploughs, disk harrow, etc., the stabilizers can be set to allow a swing of more than 5 or 6 cm (2"2.4").
- With graders, rollers, holes, weeders etc, adjust the stabilizers to restrict the side swing of the lower links.
- When transporting implements that are mounted on the three-point linkage, lateral swing must be eliminated by tightening the stabilizers.

## 4. OPERATION

### To Adjust the Stabilizers :

- Turn clockwise to increase lateral swing.
- Turn anti-clockwise to reduce swing.

NOTE - When an implement is raised to on-road transport position, lateral swing of the three-point linkage must be reduced.

### 4.39 Hydraulic Controls Operations

The power-lift control levers are used to set the following:

- Position Control (A)
- Draft Control (B)
- Mixed Control (combination of position & draft)

#### Position Control Operation

Position control is used to raise, hold and lower three point linkage for mounted implements during tillage/field operation e.g. Mounted Disc Harrow, Seed Drill, Rotavator, Disc Plough etc., which works above the ground. Once the height of implement is set, position lever maintains it. Always use Position lever for transporting the implement. One adjustable locking knob is provided for maintaining the specific position.

#### Draft Control Operation

Automatic Draft Control is designed to respond at the time of sudden resistance faced by the mounted dragging type implements i.e. Cultivator, Plough, and Reversible Plough etc. while working in the field. Keep both position and draft lever (2) in lower most position (implement grounded) now move the draft lever (1) towards up side position on sector as implement starts rising move back the lever by few mm.

**Prevents:** Overloading of engine, breakage of implements, clutch slippage, tyre slippage, and excess fuel consumption.

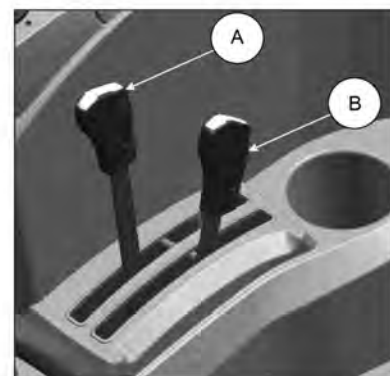

ITL000193

#### Mixed Control Operation

Simultaneous use of position control and draft control lever is called mix control. If the ground is not uniform and has soft areas where the implement can sink too deep then mix control is performed because in this situation draft control does not function properly. Use the same procedure as for work in draft control then draw a furrow up the field, when the ground becomes sandy, the implement tends to sink in deeply. In this case, bring the position control lever backward to limit the working depth. Now set the position lever in this position.

## 4. OPERATION

### 4.40 Top Link Attachment to Rocker Base

The Rocker bracket has three holes for hitching the implement and adjusting its slant. It also provides a means of adjusting draft control sensitivity. Which should be chosen according to soil conditions.

<b>A</b>	<b>Upper Hole</b>	<b>For Transportation</b>
<b>B</b>	<b>Middle Hole</b>	<b>For Hard Soil</b>
<b>C</b>	<b>Lower Hole</b>	<b>For Soft Soil</b>



**WARNING** : Never tow with the top link connected to the swinging support of the hydraulic power lift.

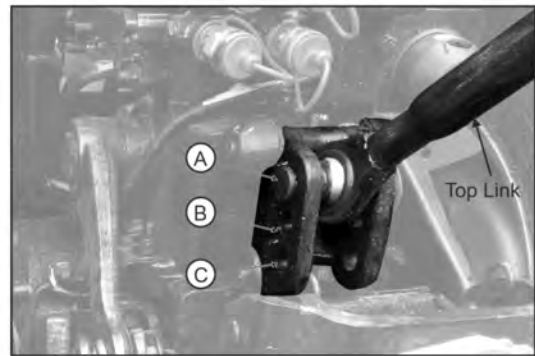

ITL000194

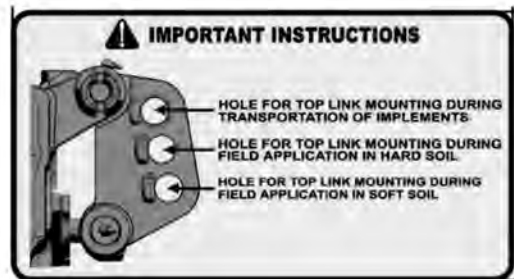

ITL000195

### 4.41 Auxiliary Circuit (2DA/3DA)

**WARNING:** Never unhitch the implements before removing the QRC's

1. Remove dust caps from hose end.
2. Pull dust plugs (D) from couplers.
3. Make sure hose end and coupler receptacles are clean.
4. Check hoses to see which is used for extending cylinder. This hose must be connected to a coupler receptacle in order for cylinder to extend when DCV levers are moved rearward or inward.
5. To connect each hose, push hose tip firmly into coupler receptacle. Pull lightly on hose to make sure positive connection was made.

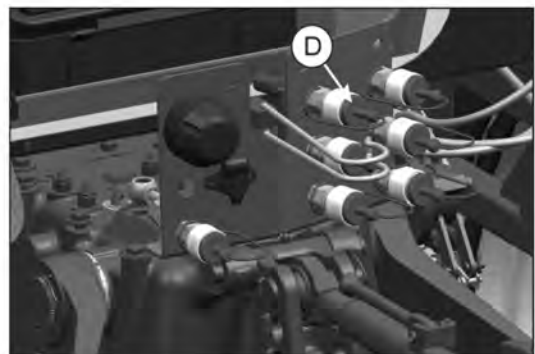

ITL000196

6. Use levers for operating the respective DCV's.



Hydraulic hoses can fail due to physical damage, kinks, age and exposure. Check hoses regularly. Replace damaged hoses.

## 4. OPERATION

### 4.42 Safety Structure (ROPS)

The tractor is equipped with a ROPS (Roll over protection safety structure mounted behind the driving seat and approved according to the CURRENT OECD and EEC STANDARDS. The protective structure is formed by two parts, one upper and one lower, which are bolted together.

The tractor must only be used with the protective structure in the upright position

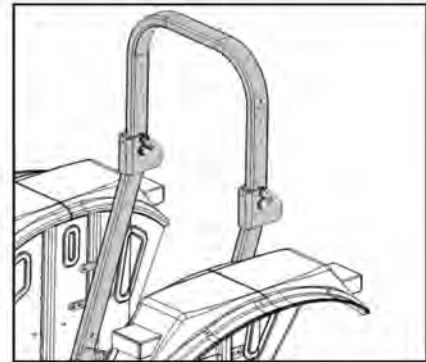

ITL000197



**WARNING** : The tractor could tip up if used incorrectly. Protection is only guaranteed when the protection structure is in original upright position with the fixing bolts tightened as described in the assembly instructions.



**WARNING** : It is absolutely forbidden to tie towing chains or ropes to the safety frame or the tractor could jack up always tow owing the proper device supplied with the tractor.



**WARNING** : Avoid injury ! Make certain all parts are installed correctly.

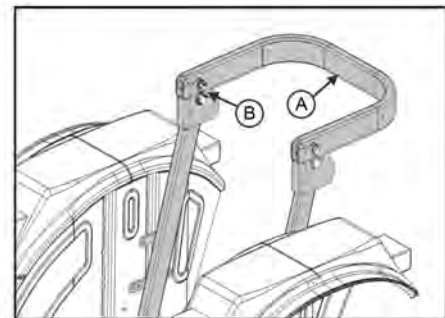

ITL000198

Safety belt can be fitted, depending on the laws in force in the various countries of use. Always wear the safety belts with the protective structure in the upright position. Never wear the safety belts when the protective structure is lowered.

If the tractor must pass through low places or be parked there for maintenance purposes and the top part of the protective structure must be folded at an angle remember that there is not enough protection for the tractor driver in this position and that he could risk serious injury. Remember that after use in low places, it is absolutely necessary to set the protective structure back in its upright position before continuing with any work.

To avoid loosening of structure the protection offered by the safety structure will be impaired if it is subjected to structure damage, as in an overturn accident, or is in anyway altered by welding, bending, drilling or cutting. A damaged safety structure should be replaced, NOT reused. Always keep upper part of the above when operating the tractor. If the tractor is operated with the safety structure folded down (e.g. to enter a low building) drive with extreme caution and DO NOT use seat belt.

Fold the safety structure up again as soon as the tractor is operated under normal conditions.

## 4. OPERATION

Comply with the following procedure if it is essential to fold down the protection structure above reason :

- Remove the pins / bolts (B) and relative nuts.
- Overturn the protective structure (A) until it resets on the stopper.
- Fit the fixing pins / bolts (B) and relative nuts as illustrated.
- Before you use the tractor again in any way, set the protective structure (A) back in the upright position by carrying out the operation described above in reverse order. Fit the fixing pins.

### 4.43 Hydraulic Valve Adjustment

Use knob (A) for locking the implement while transport or to control the speed of lifting and lowering the implement. Rotate clockwise to lock it.

Use knob (B) for controlling the draft sensing of the implement. Use only if no sensing is observed or hunting is observed.



Response valve should always be closed during implements transportation.

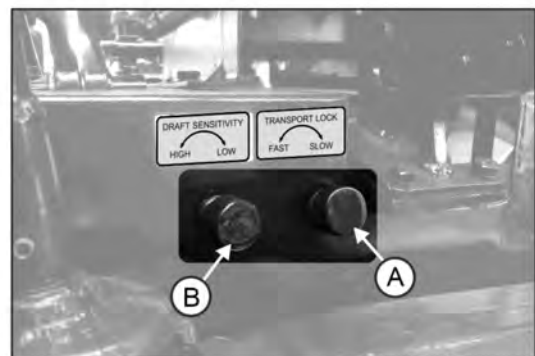

ITL000199

## 4. OPERATION

### 4.44 Auto Lift

Auto Lift switch is provided on right fender, for easy reach of operator. Best suitable in applications where immediate lifting and lowering of hydraulic linkage is required without disturbing the original position of lift with the levers.

#### Auto Lift

- For lifting the implement to top position without operation of levers.
- One touch lifting and dropping of implement.
- Pressing switch will lower the lift. Keep this lever pressed for normal working of lift.
- Releasing switch will raise the lift to top position.

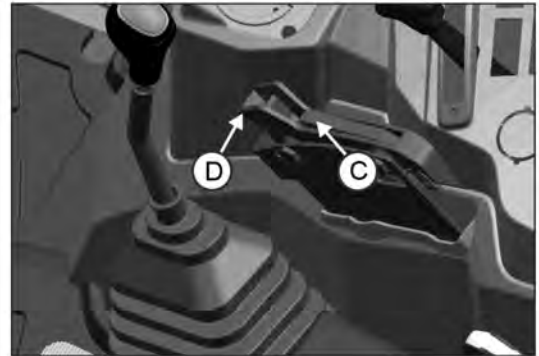

ITL000200

### 4.45 Four Wheel Drive (4WD) Operation

Move the 2WD/4WD lever (E) in backward is engage 4WD. Follow the reverse to disengage the 4WD lever Dashboard Indicator shall glow on 4WD engagement to indicate the 4WD mode .

The purpose of the front drive is to increase traction on broken ground, mud and slippery surfaces. Both maneuvers can be carried out whilst the tractor is driving in a straight line and never under stress.

NOTE: Use 4WD only when strictly necessary. Avoid use of 4WD when maximum traction is not required, e. g. on hard ground, roads etc. Always use 4WD when parking on slopes with trailer connected.



ITL000201



Never use the 4WD mode while driving at speed > 15 kmph or down the hill. Always use when high traction is required.

## 4. OPERATION

### 4.46 Tractor Transport

#### Towing the tractor

If you need to tow or push the tractor for a short distance, remember that the power steering system will allow you to drive and steer it for a short way with the engine off. Follow below rules

Ensure the following controls in Neutral position:

- Gearshift Lever
- Range Selector Lever
- Disengage the Parking Brake
- Ensure that the PTO Lever (Mechanical Version) is disengage position.
- Brake Pedals
- Tow or push the tractor at moderate speed.
- Use only a rigid towing bar and safety chains to pull the tractor due to possible loss of steering and brakes when the tractor engine is not running.

#### Transporting the tractor

The tractor must be transported with a suitable vehicle.

Engage the parking brake.

Firmly fasten the tractor to the transport vehicle using suitable chains or straps. Use the tow bar or its supports as rear fixing points for the tractor.



Never hitch or connect chains around the tractor components as these could be damaged by the chains themselves or by excessive loads.



ITL000202



**WARNING:** Make sure that the weight of a trailed vehicle that is not equipped with brakes, Never Exceeds the weight of the machine that is towing the vehicle. Stopping distance increases with increasing speed as the weight of the towed load increases, especially on hills and slopes.

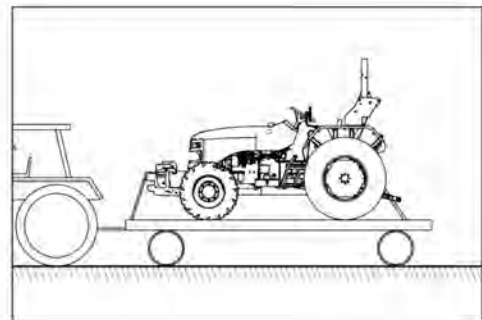

ITL000204



## 4. OPERATION

### 4.47 Front Loader Mounting Points

Front-loader brackets must be installed as shown; the screws must be tightened to the specified torque. Check torque regularly.

**IMPORTANT:**

When installing front-loader brackets, use appropriate hardware only.

Refer Operator's Manual and Installation Instructions of front loader.

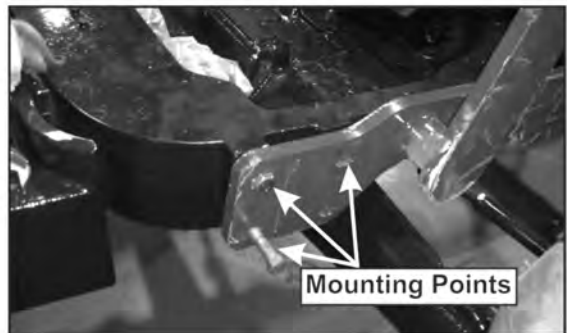

ITL000205

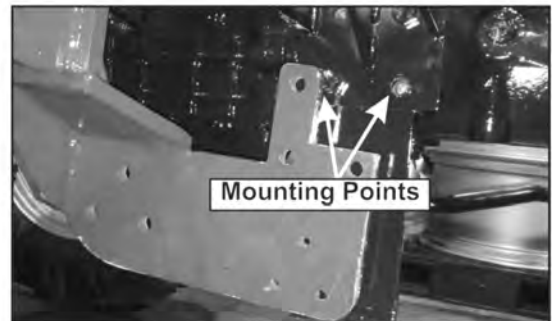

ITL000206

## 4. OPERATION

### 4.48 Jack Up the Tractor - Lifting Points

The illustrations show the recommended lifting points for jacking up the tractor. Use a stable lifting jack with sufficient lifting force.

#### Raise Rear of the Tractor

A - Wooden Wedges

B- Raise rear of the tractor by placing jack below transmission housing (use wooden wedges between front axle support and front axle beam to prevent axle from tilting)

Raise Front of the Tractor:

C - Raise Right End of Axle, e. g. to Remove Right Front Wheel. For additional safety, use wooden wedges at left side in between Front Axle and Front Axle Bracket.

D - Raise Left End of Axle, e.g. to Remove Left Front Wheel. For additional safety, use wooden wedges at right side in between Front Axle and Front Axle Bracket.

E - Raise Front End of Tractor under the Basic Weight.



Use approved lifting equipment only. Ě Jack up tractor on firm, level ground only. Ě Before doing any further work on the tractor, first secure it using suitable support stands.



ITL000207

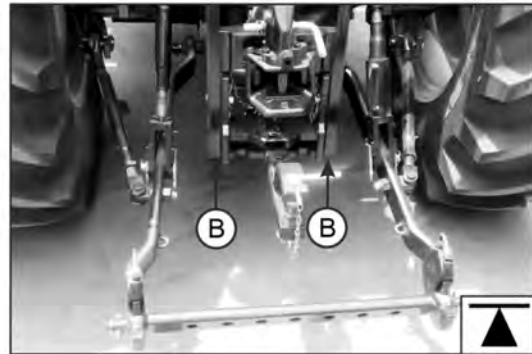

ITL000208

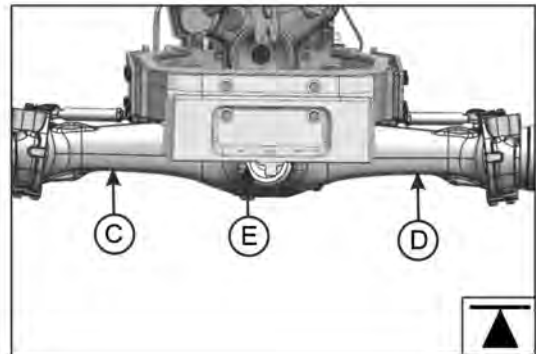

ITL000209

## 5. MAINTENANCE

### 5.1 Routine Maintenance Table

LEGENDS :			
A — ADJUST	G — GREASE	T — TIGHTEN	C/P — CHECK / TOP UP
C — CHECK	K — CLEAN	W — WASHING	C/T — CHECK / TIGHT
D — DRAIN	R — REPLACE	C/A — CHECK / ADJUST	

MAINTENANCE INTERVAL (HOURS)	EVERY 10	50	250	500	750	1000	1250	1500	1750	2000
<b>SERVICE ITEM</b>										
<b>GENERAL</b>										
COMPLETE WASHING	-	W	W	W	W	W	W	W	W	W
NIPPLE GREASING	-	G	G	G	G	G	G	G	G	G
COOLANT LEVEL	C	C	C	C	C	C	C	C	C	C
<b>AIR CLEANER</b>										
AIR CLEANER ELEMENT PRIMARY (DRY)	-	K	K	K	R	K	K	R	K	K
AIR CLEANER ELEMENT SECONDARY (DRY)	REPLACE ONCE A YEAR OR AFTER 3 REPLACEMENT OF PRIMARY ELEMENT									
AIR INTAKE HOSE CLAMPS	C/T	C/T	C/T	C/T	C/T	C/T	C/T	C/T	C/T	C/T
<b>ENGINE</b>										
ENGINE VALVE CLEARANCE	-	-	-	C/A	-	C/A	-	C/A	-	C/A
ENGINE OIL & OIL FILTER	-	R	R	R	R	R	R	R	R	R
ENGINE IDLE SPEED	-	C/A	C/A	C/A	C/A	C/A	C/A	C/A	C/A	C/A
TURBO-CHARGER INTAKE HOSE CLAMP	-	C/T	C/T	C/T	C/T	C/T	C/T	C/T	C/T	C/T
BELL HOUSING MOUNTING NUT & BOLTS	-	C/T	C/T	C/T	C/T	C/T	C/T	C/T	C/T	C/T
<b>COOLING SYSTEM</b>										
FAN BELT TENSION	C/T	C/T	C/T	C/T	C/T	C/T	C/T	C/T	C/T	C/T
COOLING SYSTEM FLUSHING	ONCE A YEAR OR AFTER 1000 HOURS									

## 5. MAINTENANCE

MAINTENANCE INTERVAL (HOURS)	EVERY 10	50	250	500	750	1000	1250	1500	1750	2000
<b>FUEL SYSTEM</b>										
FUEL FILTER (SPIN ON TYPE)	D	D	D	R	D	R	D	R	D	R
PRE-FILTER FOR FUEL	-	-	R	-	R	-	R	-	R	-
<b>CLUTCH</b>										
CLUTCH OPERATION & PEDAL FREE PLAY	C/A	C/A	C/A	C/A	C/A	C/A	C/A	C/A	C/A	C/A
<b>TRANSMISSION/HYDRAULICS</b>										
OPERATION OF GEARS	-	C	C	C	C	C	C	C	C	C
TRANSMISSION / HYDRAULIC OIL	-	C/P	C/P	R	C/P	C/P	C/P	R	C/P	C/P
TRANSMISSION / HYDRAULIC OIL FILTER	-	R	R	R	R	R	R	R	R	R
MAGNETIC STRAINER	-	K	K	K	R	K	K	R	K	K
TRANSMISSION BREATHER ASSY	K	K	K	K	K	K	K	K	K	K
OPERATION OF HYDRAULICS	-	C	C	C	C	C	C	C	C	C
HYDRAULIC HOSES AND CLAMPS FOR TIGHTNESS	-	C	C	C	C	C	C	C	C	C
<b>BRAKES</b>										
BRAKE OPERATION	-	C	C	C	C	C	C	C	C	C
BRAKE PEDAL FREE PLAY	-	C/A	C/A	C/A	C/A	C/A	C/A	C/A	C/A	C/A
<b>STEERING</b>										
STEERING OPERATION	-	C	C	C	C	C	C	C	C	C
STEERING TANK OIL	-	R	C/P	C/P	R	C/P	C/P	R	C/P	C/P
STEERING OIL STRAINER FILTER	-	R	K	K	R	K	K	R	K	K
KING PIN	-	G	G	G	G	G	G	G	G	G
TOE IN (FRONT TYRE)	-	C/A	C/A	C/A	C/A	C/A	C/A	C/A	C/A	C/A

## 5. MAINTENANCE

MAINTENANCE INTERVAL (HOURS)	EVERY 10	50	250	500	750	1000	1250	1500	1750	2000
<b>FRONT AND REAR AXLE</b>										
STUB AXLE GREASE	-	G	G	G	G	G	G	G	G	G
WHEEL BEARING GREASE	-	-	G	-	G	-	G	-	G	-
<b>FRONT AXLE 4X4</b>										
*FRONT HUB OIL (4X4)	-	C	R	C	C	C	C	R	C	C
*DIFFERENTIAL OIL (4X4)	-	C	R	C	C	C	C	R	C	C
BREATHER ASSY. (4X4)	-	K	K	K	R	K	K	R	K	K
<b>WHEELS AND TYRES</b>										
WHEEL NUTS AND BOLTS	-	C/T	C/T	C/T	C/T	C/T	C/T	C/T	C/T	C/T
TYRE INFLATION PRESSURE	-	C/A	C/A	C/A	C/A	C/A	C/A	C/A	C/A	C/A
<b>BATTERY</b>										
BATTERY ELECTROLYTE LEVEL	-	C	C	C	C	C	C	C	C	C
BATTERY TERMINALS	-	K	K	K	K	K	K	K	K	K
<b>METER /GAUGES</b>										
FUNCTIONING OF OIL GAUGE	C	C	C	C	C	C	C	C	C	C
FUNCTIONING OF TEMP GAUGE	C	C	C	C	C	C	C	C	C	C
FUNCTIONING OF ALL WARNING LIGHTS	C	C	C	C	C	C	C	C	C	C

## 5. MAINTENANCE

MAINTENANCE INTERVAL (HOURS)	Daily	50	250	500	750	1000	1250	1500	1750	2000	2500	3000
CHECK AND CLEAN EGR COOLER	-	-	-	-	-	-	-	C/K	-	-	-	C/K
CHECK & CLEAN EXHAUST MANIFOLD	-	-	-	-	-	-	-	C/K	-	-	-	C/K
CHECK & CLEAN CRANK CASE BREATHER	-	-	-	-	-	-	-	C/K	-	-	-	C/K
CHECK, CLEAN & TEST FUEL INJECTOR	-	-	-	-	-	-	-	-	-	-	-	C/K
CHECK & CLEAN EGR VALVE (replaced if required)	-	-	-	-	-	-	-	C	-	-	-	C/K

The above maintenance schedule is applied to tractors which are operated under normal conditions. When your tractor is frequently operated in muddy conditions, greasing must be carried out more frequently and when the tractor is frequently operated in dusty conditions, clean the air cleaner element and fuel filter more frequently. Extra servicing must be carried out according to particular situation.

### NOTE :

1. For emission control warranty, all maintenance to be done at dealer/distributor end only.
2. If required, replace all hoses after every 2000 hrs.
3. This schedule will be followed till engine/vehicle useful life.

### IMPORTANT

- Engine Oil grade should be selected as per operating temperature condition.
- Anti freeze should be used in sub zero ambient temperature.
- Clean Air Cleaner element as and when required as per field operating conditions.
- Clean Strainer filter of Power Steering Tank when any rework of pressure line.
- Clutch pedal play should be adjusted as per field operating conditions.

## 5. MAINTENANCE

### 5.2 Fuel Tank Filling



Comply with the following instructions when working with the diesel fuel:

1. Do not smoke while filling the fuel tank because diesel is flammable liquid and catch fire easily.
  2. Mixtures of diesel fuel and alcohol are not approved since the resulting lubrication of the fuel injection system is insufficient.
  3. Clean the area around the filler neck where the fuel is poured.
  4. Fill the tank at the end of the day to prevent the formation of overnight condensation.
  5. Never remove the plug or fuel the tractor while the engine is running. Keep control of the pump nozzle whilst the tank is being filled.
  6. The tank must not be completely filled. Allow space for an increase in volume. If the original tank plug is lost, it must be replaced with an original spare which must be fully tightened.
  7. Dry up any fuel spill immediately.
- Store fuel cans away from direct sunlight and slightly tilted, so that any sediment inside is eliminated through the outlet tube.
  - To make sludge and water condensation easier to remove; there should be a discharge plug (c), in the lowest point, on the opposite side to the drain tube.
  - If the fuel is not filtered from the storage can, use a funnel with the fine gauge mesh over the fuel tank fill plug inlet when fueling.
  - Plan your fuel purchases so that summer fuels are not kept for too long and used in the winter.

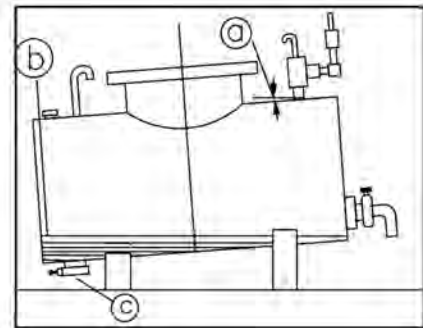

ITL000210

#### Fuel Requisites

It is important to use good quality fuel for the long life & good performance of the engine. The fuels must be clean, well refined and non-corrosive for the fuel system components. Make sure that you use fuel of a known quality and reliable origin.

#### Fueling

Before you fuel the tractor, clean the zone around the filler neck to prevent foreign bodies from entering the tank. After fuelling, tighten the plug properly.

#### Fuel Storage (A)

Take all the necessary precautions to ensure that stored fuel does not become polluted with dirt, water or other substances.

Store fuel in black iron cans. Do not store it in galvanized cans as the galvanization treatment would react with the fuel and form compounds that would spoil the injection pump and injectors.

- a- Slope at 25%
- b- Condensation water
- c- Sludge drain plug



ITL000211

## 5. MAINTENANCE

### 5.3 Maintenance of Air Cleaner (Dry)

- Clean the primary element at first 50 hours and then after every 250 hours of operation or whenever clogging indicator glows on dashboard.

A — Air Cleaner Assembly

B — Air Clogging Sensor

C — Rubber Valve

- Replace primary element after 3 times cleaning or 750 hrs, whichever is earlier.
- Gently pull primary element back and forth to take it out from housing.
- Clean primary filter element by blowing air (max. pressure not more than 1.6 bar) from inside.
- Secondary element not to be removed during cleaning of primary element. Secondary element to be replaced once a year or after every three replacement of primary filter.
- Do not clean Secondary element by compressed air.
- Use clean cloth to wipe sealing areas of primary filter.
- Ensure proper seating of filter into housing before latching the cover. Do not use latches on the cover to force the filter into air cleaner that could cause damage to housing and will void the warranty.
- Ensure proper seating of all rubber rings, replace the damaged ones.
- Discharge the dust deposits and sediments daily by pressing the rubber valve on the air cleaner housing.

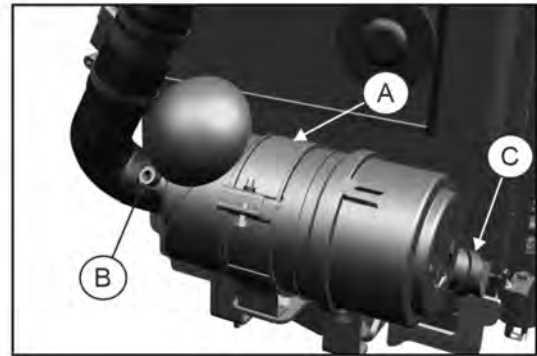

ITL000212

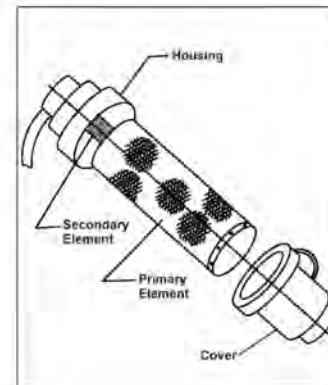

ITL000213

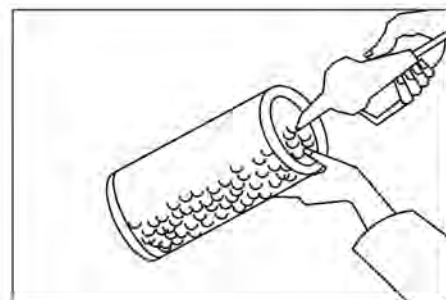

ITL000214



**IMPORTANT:** NEVER attempt to clean the filter element with exhaust gas from the engine. NEVER ever use oil on dry filter. NEVER ever use oil, diesel fuel, paraffin or solvents to clean the filter element.



## 5. MAINTENANCE

### 5.4 Engine Oil Level

Leave the tractor parked on a leveled surface for at least five minutes before checking the level, to allow the oil to settle in the sump.

Take out the Dipstick (A) by unscrewing it, wipe it with a rag and then dip it into sump again, then remove the dipstick again and ensure that the oil level is within the upper/lower mark reaches and does not exceed the upper mark.

If necessary, add recommended engine oil through the oil filler until the required level has been reached.

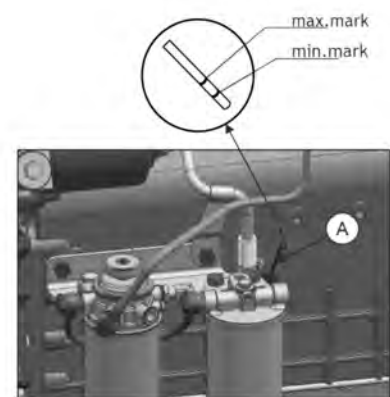

ITL000215



Never ever use the engine with the oil level below the Minimum Mark.

### 5.5 Replacement of Engine Oil & Engine Oil Filter

1. Stop your tractor to the side of road on leveled surface and drain the engine oil in an oil pan after removing the drain plug.
2. Remove the oil filter by rotating it in anti-clockwise direction by hand or with the filter wrench.
3. Take new oil filter (B) and check it for proper seating of gasket.
4. Apply clean engine oil to gasket on the new oil filter.
5. Install oil filter. When the filter gasket contacts the mounting surface of filter, tighten the new oil filter.

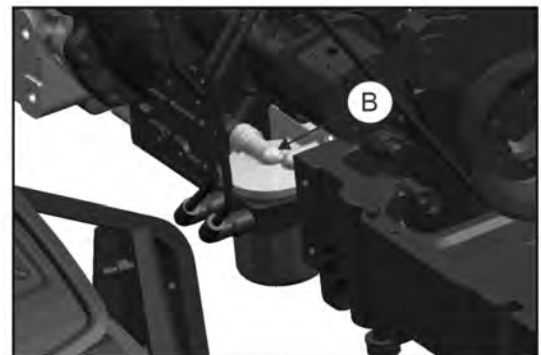

ITL000216

## 5. MAINTENANCE

### Refilling Engine Oil (C):

- During the running in period, the engine oil must be changed after first 50 hours. Following this, change Engine oil at every service.
- Drain the oil when engine is hot.
- Remove drain plug after parking the tractor on leveled surface.
- Allow the tractor to cool down.
- Fit the drain plug and tighten to recommended torque.
- Fill up oil through oil filler until it reaches to the MAX mark on the dipstick.
- Check the oil pan and other parts for oil leakage.

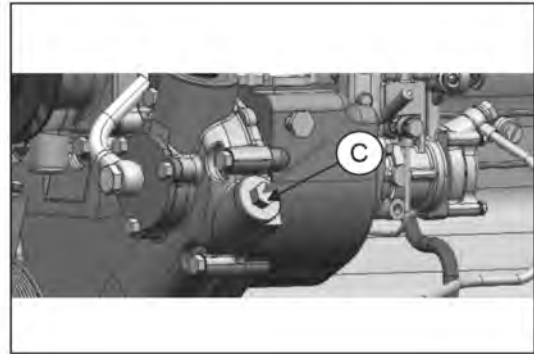

ITL000217



**CAUTION:** Only use genuine filter cartridges. Use of non-genuine cartridges could damage the engine and shorten its working life.

## 5. MAINTENANCE

### 5.6 Replacement of Spin-on Fuel Filter

- Close the fuel supply.
- Disconnect the connector from sensor (D).
- Remove the filter (A) by rotating it anti-clockwise direction by hand or special wrench.
- Take new fuel filter and replace it.
- Open the fuel supply.
- Slightly loose the bleed screw (B) and operate the hand priming pump (C).
- Start the engine and check for leakages.

Replacement schedule: Every 500 Hrs.

To drain the water from filter (A) disconnect the connector from sensor (D) and rotate the clockwise to remove the sensor.

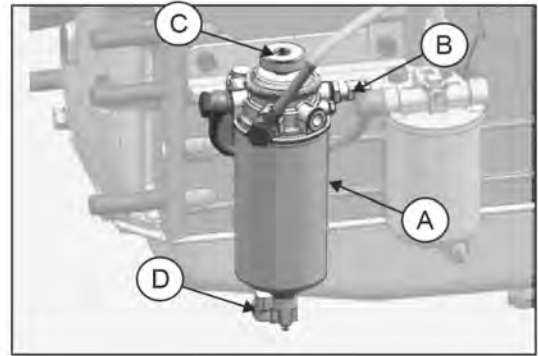

ITL000218

### Replacement of Pre Filter (E)

Replace the pre-filter at first 250 hours service and following this change the pre-filter after every 500 hours interval.

- Remove the screw (F) to replaced the pre-fuel filter body (E).
- Take a new filter element and check it for proper seating of gasket.
- Apply clean engine oil to gasket on new filter.
- Install pre-fuel filter body, when the filter gasket contacts the mounting surface of filter, tighten the filter and ensure that there is no leakage.

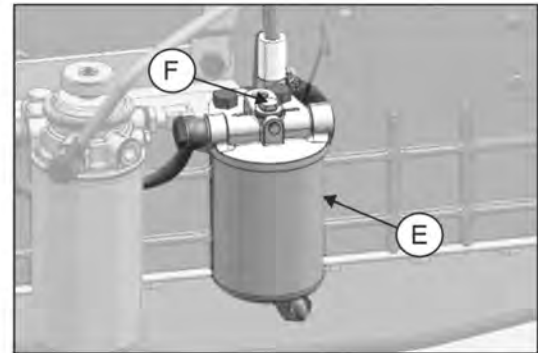

ITL000219

## 5. MAINTENANCE

### 5.7 Radiator

#### Coolant Level in Radiator (Hot)

Slowly open the radiator cap up to the safety catch (about 1/3 turn). Wait to allow the steam to escape. Continue opening the cap, press it down firmly to release the safety catch. The level of coolant should just touch the tab located in the filling spout.

If the level has dropped, check the entire cooling system for leakage (radiator, hoses etc.) If there is no leakage, Top up the coolant.

Fill the reserve tank with coolant up to the FULL line mark for coolant top up.

Coolant is mixture of water and anti scaling / anti rusting agent in recommended ratio.

**In Sub Zero Temperature climate conditions use Ethylene Glycol Antifreeze Agent along with water in following ratio:**

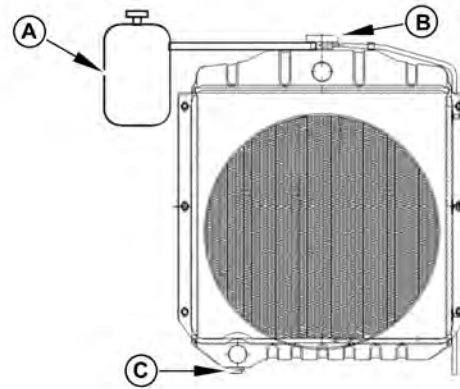

ITL000220

**A — Reserve tank**

**B — Radiator Cap**

**C — Drain Plug**

Temperature Range 0C	0 to -3	-3 to -8	-8 to -16	-16 to -25	-25 to -37	-37 to -55
Antifreeze (%)	10	20	30	40	50	60

Coolant can be permanent maintained in the circuit for 1 year so long as you have not totalized 1000 hours service during this period. In this case, the mixture must be changed.

## 5. MAINTENANCE

### Radiator Draining & Flushing (when Cold)

1. Remove the radiator cap and drain plug.
2. Let the coolant drain out. Close drain cock and plugs. Flush the cooling system with water / Cleaning Solution for 15 minutes, then drain the cleaning solution.
3. Refit the drain plug and refill the coolant (Mixture of water and anti scaling agent / antifreeze).
4. Run the engine with radiator cap open and accelerate 2-3 times and Top up coolant, if required.
5. Refit the radiator cap and ensure tightness all the connections for any leakage.

### Radiator & Intercooler Fins Cleaning

1. Check radiator & intercooler Fins for holes or cracks for chocking.
2. To clean the radiator & intercooler, blow compressed air from engine side to outside.

### Radiator Cap

Cooling system is closed pressurized system so don't operate the tractor without radiator cap or cap with damaged rubber seals/defective release valve to avoid water loss and engine overheating.

Use genuine radiator cap only

### Thrash Guard Cleaning

1. Thrash Guard is provided in front of Radiator Assembly to avoid to frequently chocking.
2. Open the LHS side cladding for removing the trash guard and clean it regularly.



**WARNING** : NEVER remove the cap from the radiator while the engine is still hot. Always unscrew the cap slowly by one position and allow the pressure to drop before you loosen it completely.



**WARNING** : These operations must be carried out when the engine is cold. When hot, the grilles and radiator will burn the hands and fingers.

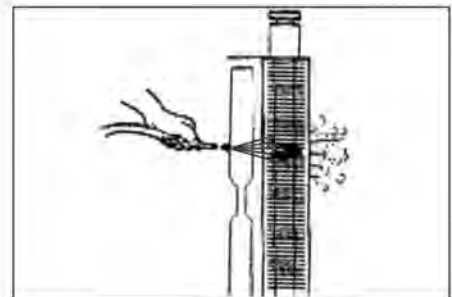

ITL000221



ITL000222

## 5. MAINTENANCE

### 5.8 Power Steering Reservoir Oil Level

Open the bonnet to access the Power steering reservoir. Take out dipstick (A) cum breather and wipe it with clean cloth and observe the oil level in the tank. If necessary pour additional oil through the dipstick hole.

(The oil filter for power steering circuit is located inside power steering reservoir.)

Unscrew the four bolts (B) of filter strainer housing cover plate then remove and Clean the filter strainer with kerosene oil / air pressure as per scheduled maintenance. Tighten the four bolts.

#### Cleaning Procedure:

1. Remove the steering tank cap.
2. Take out the oil strainer.
3. Clean it with kerosene oil / air pressure.
4. Reinstall.

**Recommended Oil Grade:** Dexron II-D.

**Oil Capacity:** 2.5 Liters.

Power steering tank oil level should be in "FULL" as Indicated in the dipstick.

**A — Dipstick**

**B — Bolts**

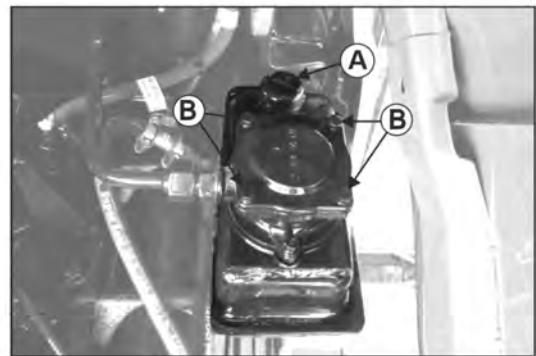

ITL000223



ITL000224

### 5.9 Transmission / Hydraulic Oil Filter

- Carefully unscrew oil filter from its adapter, Use of Filter wrench may be necessary.
- Clean the filter adapter and lubricate rubber seal on replacement filter with clean hydraulic oil. Install new filter duly filled with clean oil and tighten by hand.
- Do not use filter wrench to tighten the filter.

**C — Transmission / Hydraulic Oil Filter**

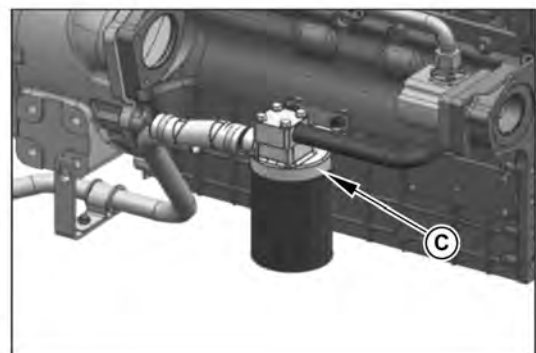

ITL000225

## 5. MAINTENANCE

### 5.10 Clutch Pedal

By pressing clutch pedal the motion and power or engine will be disengage from gearbox. Release the clutch pedal slowly for transfer the engine power to gear box.

#### Method to Check Clutch Pedal Free Play

Press down the clutch pedal and measure the free play of pedal as shown in the figure. The distance should be 20 to 25 mm. If the distance is less than 20 mm or higher than 25 mm then get it adjusted.

**IMPORTANT:** Do not keep foot on clutch pedal while tractor is in running condition. It may cause excessive wear of clutch and clutch falls before its life time.

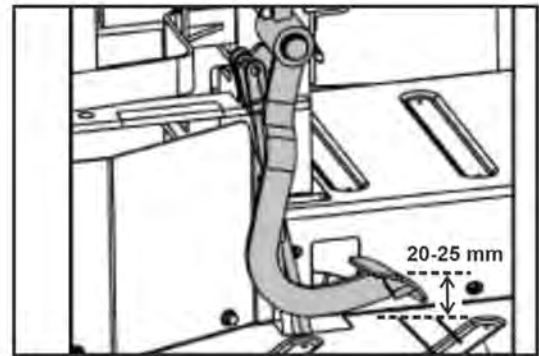

ITL000226

### 5.11 Foot Brake Pedals

Use independent brake in the field operations. In field you will turn more sharply by pressing brake pedal for the side wheel on the turn. The pedals must be locked for road use.

#### Method To Check Brakes

Release the hand brake. Uncouple the two pedals.

Press down the right hand pedal and measure the free play of pedal as shown in the figure. The distance should be between 50-55 mm.

If the free play is less than 50 mm or higher than 55 mm then adjust the both hex nut on actuator tie rod until free play comes to 50 to 55 mm. Now, press down the left hand pedal. If the values are not equal with the right hand pedal then repeat the same procedure until values come equal.

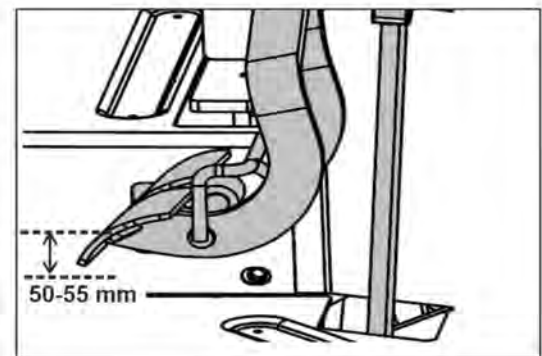

ITL000227



Difference in the free play will lead to unbalanced brakes, the tractor can slew in the event of violent braking. The wheel on which the brakes are applied locks and the tyre wears out quickly. During Road Operations both the brake Pedals should be locked.

## 5. MAINTENANCE

### 5.12 Oil Changes in 4WD Front Axle (optional feature)

#### Axle housing

- Place a vessel under the drain plug .
- Remove the drain plug (A), drain out all the oil.
- Fit the plug back when no more oil is coming out.
- Fill up with fresh oil through filler plug (B) up to the level of filler hole.
- Wait for the oil to stabilize before checking the level.
- Top up is necessary.
- Fit the plug back.

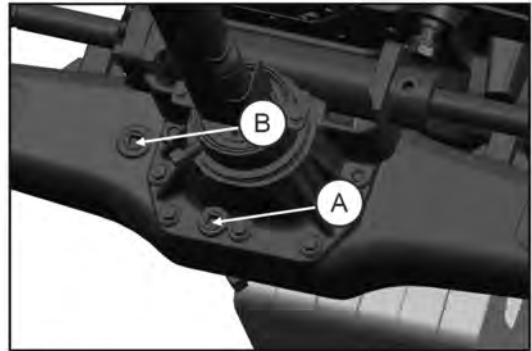

ITL000228

**A — Drain Plug**

**B — Filler Plug**

#### Side final drives

- Position the final drive plugs downward (Oil drain).
  - Place a vessel under each final drive plug (one for each final drive).
  - Remove the plugs and drain out all oil.
  - Position the plugs (Refilling) on the wheel center line.
- Fill up with oil of the specified type to the level of the holes.
  - Wait for the oil to stabilize before checking the level.
  - Top up if necessary.
  - Fit the plug back.

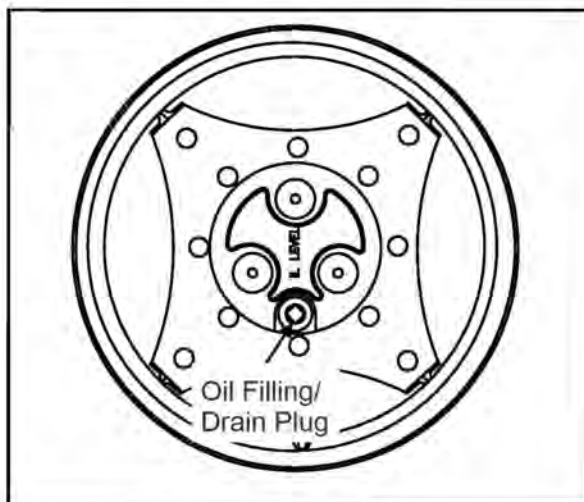

**Oil Drain**

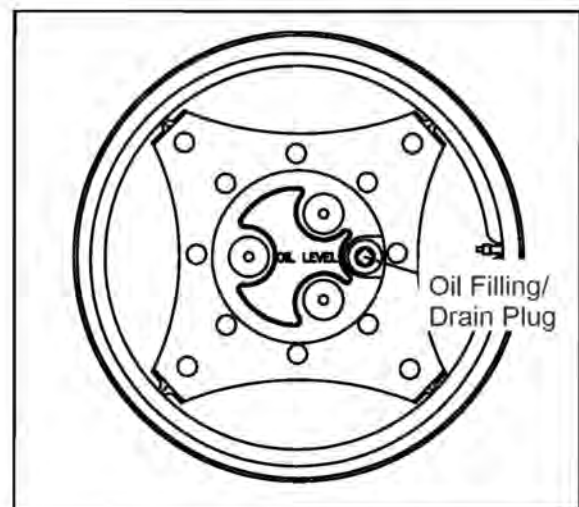

**Refilling**

ITL000234



## 5. MAINTENANCE

### 5.13 Oil Changes for Transmission, Rear Final Drives and Power Lift Hydraulic Circuits

**NOTE:** It is advisable to change the oil in the gear box for the first time after 500 hours, then after every 1000 hours service.

**NOTE:** When draining out and filling oil and checking oil level, take care that the transmission is in horizontal position.

#### Oil Draining

- Park the tractor on plane surface.
- Keep the vessel under drain plug.
- Unscrew and remove the drain plug and drain oil.



Beware of powerful oil jets. Follow all safety rules.

- Clean the plugs and fit back on.

#### Filling up the transmission

1. Fill up recommended grade oil from filler plug (C).
2. Put the gearshift lever in neutral and start the Engine. Let it run on idle until the oil reaches a temperature over 25°C.
3. Check that the transmission oil level mark on the dipstick (B).
4. If required, fill up to the correct level.

**NOTE :** Let the oil stabilize before checking its level.

**IMPORTANT:** See the Lubricants and Fuel chart for the type of oil to be used according to the transmission type.

**NOTE:** If implement used require more quantity of oil, make sure that the transmission contains enough oil for every work condition. Top up as required.

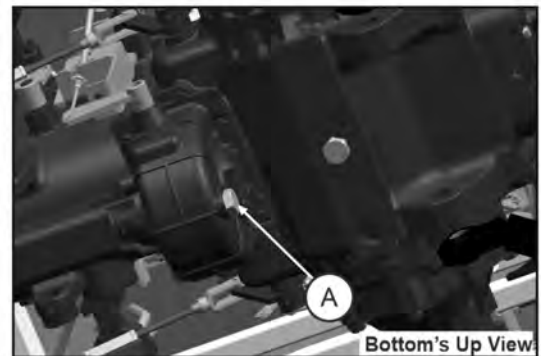

ITL000230

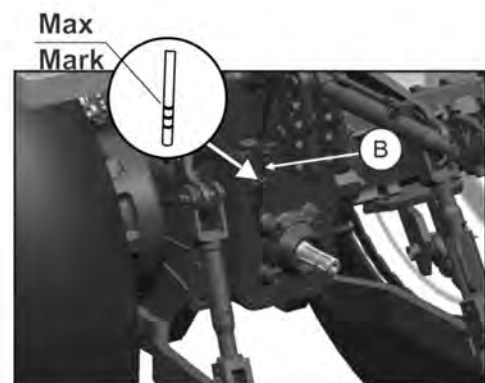

ITL000231



ITL000232

## 5. MAINTENANCE

### Recommended Oil Grade & Application Range

We recommend use of **SAE-80W** oil grade comply to **API GL4 - GL5** for transmission and Oil brakes.

Refer the chart for appropriate oil viscosity according to the ambient temperature.

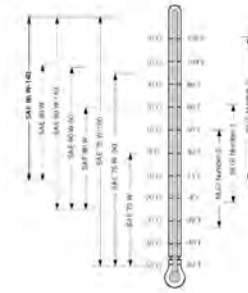

ITL000233

### Recommended oil viscosity according to air temperature.

### 5.14 Cleaning of Suction Strainer

At each oil change, thoroughly clean suction strainer by washing with light oil or kerosene.

Failure to observe this will result in extensive shortening life of hydraulic system.

#### Cleaning Procedure of Suction Strainer:

1. Remove all hose warm clips (1).
2. Separate the Hose pipes (2) from Strainer Assy.
3. Hold the strainer assembly in left hand & remove the wire clip (5) & magnetic strainer (4) from the housing (3) with the help of right hand fingers.
4. Unscrew the nut (6) & remove supporting cup (7). After dis-assembling supporting cup remove the sheath (8) having ferrous dust by sliding it with the help of plastic support (10).
5. Clean the sheath from ferrous dust with the help of soft cloth and refit the same.
6. Assemble the supporting cup & tighten the nut.
7. Assemble magnetic strainer in strainer housing and lock it with the wire clip.
8. Fix the hose pipes and tighten the hose warm clips.

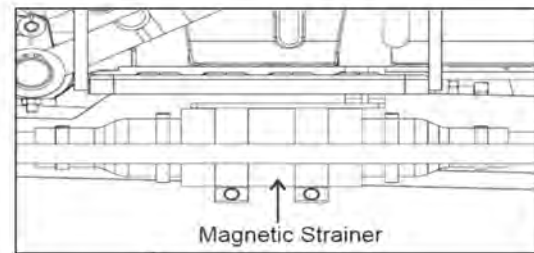

ITL000235

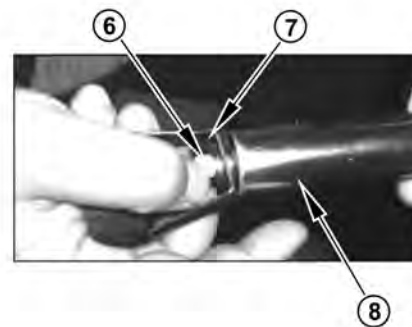

ITL000236

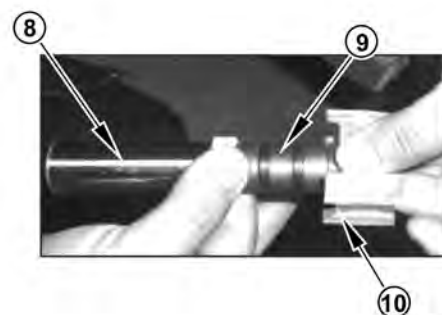

ITL000237

**Replacement:** Replace the magnetic strainer at every 750 Hours.

## 5. MAINTENANCE

**IMPORTANT:** Do not dismantle the magnets (9) as these are assembled in polarity sequence and it should not be disturbed.

### 5.15 Inspection of Hoses

Check hose clamps of the following systems for tightness:

- Air Cleaner to engine intake or turbocharger.
- Cooling system
- Hydraulic system
- Fuel system

Check all hoses for cracks which could cause leaks or possible failure. Replace as necessary.

#### Check/Replace Hydraulic Hoses:

- Check hydraulic hoses regularly (On every service / before cranking/ after long idle) for leaks, kinks, cuts, tears, rubbing, bulges, corrosion, exposed fabric and other signs of wear and damage.
- Replace worn or damaged hoses immediately.
- Replacement hoses are available at your dealer.



**NOTE:** Refer Maintenance Schedule for Inspection interval of Hoses.

### 5.16 General Maintenance of Electrical System

- Never Patch up the electrical circuits.
- Never replace a blown fuse by a higher capacity fuse. It could cause a fire.
- Never work on components such as the alternator or starter motor when the engine is running.
- Lastly when you are cleaning the tractor and using the pressure spray, take care not to damage the connections on the various electrical cable.

## 5. MAINTENANCE

### 5.17 Battery and its Maintenance

#### Battery removal procedure:

- Remove the lock pin (A).
- Unscrew the lock nut (B).
- Pull and rotate the front panel of battery box to right as shown in the figure .
- Unscrew the lock nuts (B) and take the battery out by using the handle.



ITL000238



**WARNING** : Check for all the clearance inside the battery box to avoid any short circuit inside the battery box



**WARNING** : NEVER top up with SULPHURIC ACID.

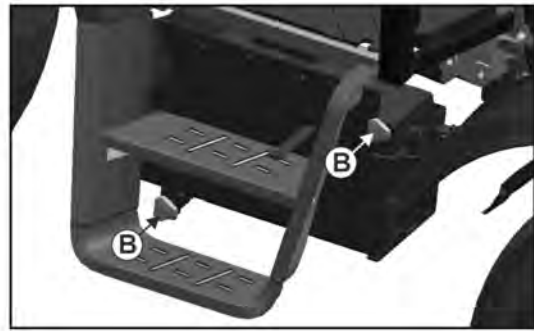

ITL000239

**IMPORTANT** : Apply terminal grease periodically to prevent corrosion of terminals

**NOTE** : Battery leads should be disconnected prior to any welding job as prevention to electrical system damage.

#### Check Electrolyte Level

It must be as per the recommendation of battery manufacturer. If required top up with distilled water. Never add acid.

#### Check Carefully Battery Charging

Protect against freezing. Insure that terminals are clean and tight. Check specific gravity of battery using a battery hydrometer.

Specific gravity of a fully charged battery is 1.265  $\pm$ 0.005 at 27 °C.

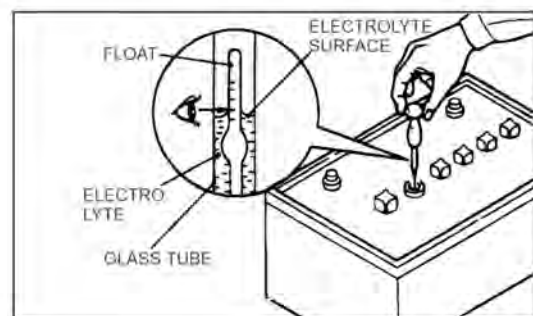

ITL000240

## 5. MAINTENANCE

### 5.18 Starter Motor

Starter motor is mounted on the right side of the engine. The starting motor rotates the engine crankshaft for starting.

Visually check the starter for damage. If starter is dusty, blow off dust using compressed air.

Note: If defects are found in the starter, contact your dealer.

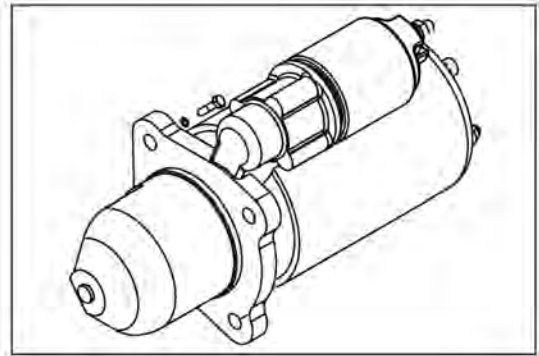

ITL000241

### 5.19 Alternator

Alternator is fitted on right side of engine and generates current which charges battery for healthy electrical back up.

Visually check the alternator for damage. If the alternator is dusty, blow off dust using compressed air.

Remove V-belt, and turn the pulley with hands to make sure it rotates smoothly.

Note: If defects are found in the alternator, contact your dealer.

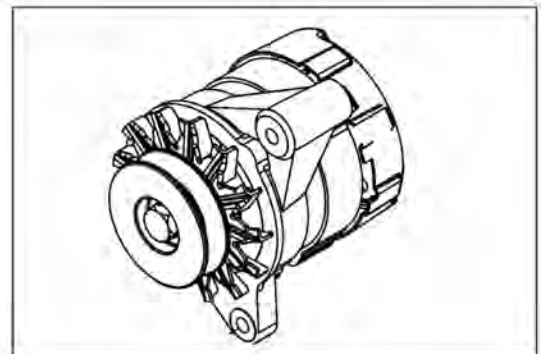

ITL000242

#### Checking Belt:

1. Ensure that Belt is free from defects such as wear, cuts or surface separations, otherwise replace with genuine specified belt.
2. Inspect belt tension by pushing the belt downward with approx. 98N (10kgf) (22lbf) force midway between pulleys. If the deflection is 10 to 12mm, the tension is correct. If the tension out of the specified value, adjust belt tension.

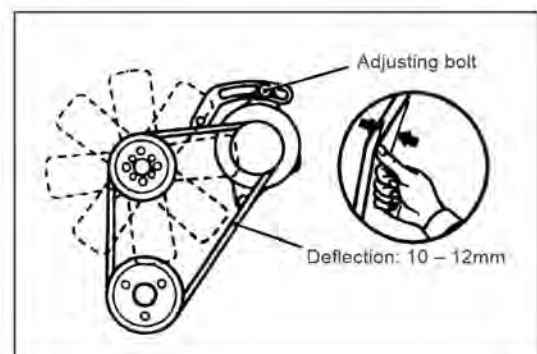

ITL000243

## 5. MAINTENANCE

### Adjusting Belt Tension:

1. Loose all retaining bolts of the alternator and adjusting plate.
2. Insert a bar between the alternator and cylinder block and use leverage to move that alternator to have proper belt tension.
3. While belt tension is appropriate, re-tighten all the retaining bolts of the alternator and adjusting plate.

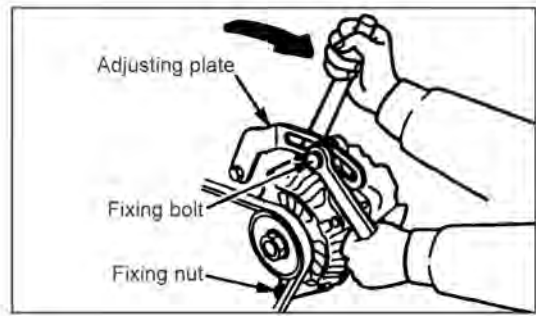

ITL000244

### 5.20 Long Idle Period

Take the following precautionary measures when your tractor is not going to be used for a long period of time.

- Park the tractor in dry sheltered place.
- Drain the coolant from the radiator and engine.
- Grease all points provided with grease nipples.
- Remove the injectors and squirt a small quantity of engine oil into the cylinders. Turn the engine over by hand, and then fit the injectors back in place.
- Generally clean the tractor particularly the bodywork components.
- Protect the painted parts by applying silicon wax and the unpainted metal parts by applying protective lubricant.
- Park the tractor in a dry, sheltered and possibly ventilated place.
- Make sure that all the controls are in neutral (including the electric switches and parking brake controls).
- Remove the ignition key from ignition switch.
- Make sure that the cylinder stems (of the power steering, power lift system, etc) are positioned.
- Empty the fuel tank and fill with it with new diesel fuel until the maximum level is reached.
- Remove the battery, clean the cover and spread Vaseline on the terminal and terminal caps. Now connect the battery in the ventilated place where the temperature is not liable to drop below 10 and where it is not exposed to direct sunlight.
- Check the battery charge with a voltmeter as described in the battery part of this section Recharge if it is necessary.
- Place stands or other supports under the axles in order to take the weight off the wheels. When the tractor is raised in this way, it is advisable to deflate the tyres.
- If this is not possible, the tire pressure must be periodically checked.
- Cover the tractor with a tarpaulin (not plastic or waterproof).



At the end of the idle period. When you start the engine again, pay particular attention to the instruction about starting engine in the "Operation" Chapter.

# 5. MAINTENANCE

## 5.21 Greasing Points

Note: Greasing points shown below may vary according to model.



King pin (LHS/RHS) (for 2WD)



Centre Pin (for 2WD)



Front hub (LHS/RHS) (for 2WD)



Tie Rod End (LHS/RHS) (for 2WD)



Centre Pin (for 4WD)



Front hub (LHS/RHS) (for 4WD)



Clutch Actuating Shaft (LHS)



Brake Pedal Shaft (LHS/RHS)



Rear Axle (LHS/RHS)



Lift Rods (LHS/RHS)



Brake Link Shaft (LHS/RHS)



Hydraulic Command Support



Rocker Link Upper Hinge



Rocker Link Lower Hinge



Draft Sensing Spindle

ITL000245

**Note :-** Grease to all the nipples after cleaning at every 50 hours for normal use and 10 hours where use for puddling application.

## 5. MAINTENANCE

### 5.22 Oil and Lubrication Chart

Aggregate	Capacity	Recommended Grade
Engine Oil	8.2 Litres	SAE-10W40 (cold weather countries) SAE-20W40 (hot weather countries)
Gearbox and Rear Axle	37.6 Litres	ELF-2412 (SAE-80W)
4 WD Front Axle	5.5 Litres	Rotra Multi THT
4 WD Front Axle (each side drive)	0.5 Litre	Rotra Multi THT
Power Steering	2.5 Litres	Dextron II-D
Coolant	12 Litres	G40 RTU Anti-freeze Grade
Fuel	72 Litres	Diesel Fuel Only
Refrigerant	750 gms	R134a
Oil AC Compressor	–	PAG 46 OR EQUIVALENT OZONE FRIENDLY



## 6. TECHNICAL SPECIFICATIONS







### 6.1 Technical Specifications:

Aggregate	Parameter	Tractor Model
		50 HP
<b>ENGINE</b>	Make	International Tractors Limited
	Engine Type	3 Cylinder CRDI with Turbo Charger & Intercooler
	Model and Identification	3105CTD
	Bore x Stroke (mm)	105 x 118
	Displacement (CC)	3065
	Emission	Stage V
	Engine Rated speed	2000 rpm
	Low Idling RPM	750 (±50) rpm
<b>TRANSMISSION</b>	Clutch Type	Dry Clutch (Finger Type), Mechanical
	Gearbox Type	Synchromesh + Range Constant-mesh (12+12)
<b>BRAKES</b>	Type	Oil Immersed Brakes (OIB)
<b>STEERING</b>	Type of Steering	Power Steering
<b>HYDRAULICS</b>	Lifting Capacity (Kg)	Std. 2200
<b>P.T.O.</b>	Type	540/540E
<b>TYRES</b>	Front Tyre Size (Std.)	9.5 X 20 8PR
	Rear Tyre Size (Std.)	13.6-28 12PR
<b>OVERALL DIMENSIONS (IN MM)</b>	Wheel Base	2216 mm
	Front Wheel Track	1576 mm
	Rear Wheel Track	1440 mm
	Length Platform/Cabin	4066 mm/4106 mm
	Width	1816 mm
	Turning radius in mm W/O Brakes	4850 mm
	Min. Ground Clearance	313.5 mm
	Gross Weight - Unladen (Kg)	Platform: 3342, With Cabin: 3470

Note: All dimensions & specifications are for guidance purpose only & are subjected to change without prior notice.

## 6. TECHNICAL SPECIFICATIONS

### 6.2 Matching Implements

Sr. No.	Implement	Platform	Cabin
1	Power Harrow 	7 Feet	8 Feet
2	Plough 	3 Bottom reversible 13 inch	3 Bottom reversible 14 inch
3	Rotavator 	9 feet (60 blade)	10 feet (66 blade)
4	Disc Harrow 	12*12 Disc (3-3.2 m)	14*14 Disc (3.4-3.6 m)
5	Cultivator 	17 Tyne Cultivator (3.8-4 m)	19 Tyne Cultivator (4.2-4.4 m)
6	Trailer 	12 Tonne, (14x7x2 feet)	15 Tonne, (16x7x2 feet)

# 7. DO'S & DONT'S

## 7.1 DO'S & DONT'S

DO'S	DONT'S
<b>ENGINE</b>	
<b>A. General</b>	
<ol style="list-style-type: none"> <li>1. Do release the starter key once the engine has started.</li> <li>2. Do check the proper functioning of oil pressure gauge and battery charging indicator once the engine has started.</li> <li>3. Do get the tightness of cylinder head and manifold nuts checked regularly.</li> </ol>	<ol style="list-style-type: none"> <li>1. Do not keep on continuously cranking the engine with starter key. It will shorten the life of battery &amp; starter.</li> <li>2. Do not race the engine in neutral or at the time of cranking.</li> </ol>
<b>B. Air Inlet System</b>	
<ol style="list-style-type: none"> <li>1. Do inspect the air element clean if necessary.</li> <li>2. Do check inlet Hose and clamps regularly.</li> </ol>	<ol style="list-style-type: none"> <li>1. Do not run the tractor if the air cleaner assembly is defective as this will lead to impure air being taken in and consequently excessive wear of liners and piston rings.</li> </ol>
<b>C. Fuel System</b>	
<ol style="list-style-type: none"> <li>1. Do drain sediments from the fuel tank periodically</li> <li>2. Do clean fuel tank thoroughly once in every 500 hrs.</li> <li>3. Do change filter regularly as per recommended service schedule.</li> <li>4. Do fill in diesel in the tank at the end of the day's work so as to avoid condensation.</li> </ol>	<ol style="list-style-type: none"> <li>1. Do not keep the fuel tank without a proper sealing cap.</li> <li>2. Do not use contaminated fuel as it may effect the operation of fuel injection pump and the injections.</li> <li>3. Do not use bad quality spurious filters as replacement.</li> <li>4. Do not allow leakage through fuel pipe joints.</li> </ol>
<b>D. Water cooling System</b>	
<ol style="list-style-type: none"> <li>1. Do ensure that radiator is always filled with clean (soft) water &amp; radiator cap is tight.</li> <li>2. Do clean the radiator front grill to ensure free flow of air when the engine is operating.</li> <li>3. Do ensure proper tension of fan belt. Deflection should not be more than (10 mm) when pressure is applied between the fan pulley and the crankshaft pulley.</li> </ol>	<ol style="list-style-type: none"> <li>1. Do not run the tractor with the radiator cap removed / nonacting radiator cap.</li> <li>2. Do not run the tractor when the radiator hoses are leaking as it will lead to or heating of the engine.</li> <li>3. Do not remove thermostat as it will effect engine performance.</li> <li>4. Do not run the belt tight as it will lead to premature failure of water pump and alternator bearing.</li> <li>5. Do not run the belt loose as it will lead to inefficient cooling and improper charging of the battery.</li> </ol>

## 7. DO'S & DONT'S

DO'S	DONT'S
<b>E. Lubrication System</b>	
<ol style="list-style-type: none"> <li>1. Do replace engine oil after first 50 hrs of operation, thereafter, engine oil should be replaced every 250 working hrs.</li> <li>2. Check oil level daily with tractor parked on a level ground.</li> <li>3. Do replace lub. oil filter element every 250 working hrs, after 1st replacement at 50 hrs.</li> <li>4. Do remove fly wheel housing bottom plug and check for oil traces.</li> </ol>	<ol style="list-style-type: none"> <li>1. Do not use wrong grade of lubrication oil.</li> <li>2. Do not mix different brands of engine oil.</li> </ol>
<b>CLUTCH</b>	
<ol style="list-style-type: none"> <li>1. Do ensure that clutch free pedal play is between 25 to 35 mm.</li> <li>2. Do ensure that the clutch pedal is released slowly while moving the tractor.</li> </ol>	<ol style="list-style-type: none"> <li>1. Do not rest the foot on the clutch pedal.</li> <li>2. Do not work the tractor by slipping and re-engaging the clutch.</li> <li>3. Do not coast down steep slopes with tractor in neutral/with clutch pedal depressed.</li> </ol>
<b>TRANSMISSION</b>	
<ol style="list-style-type: none"> <li>1. Do change the transmission oil after every 1000 hours of operation. First oil change is at 500 hours.</li> <li>2. Do check the condition of rubber protection bellows on the gear levers periodically as they prevent infiltration of water and dust into gear box.</li> </ol>	<ol style="list-style-type: none"> <li>1. Do not use top gears with low engine rpm.</li> </ol>
<b>HYDRAULIC SYSTEM &amp; LINKAGE</b>	
<ol style="list-style-type: none"> <li>1. Do ensure that both hydraulic control levers are in down position while draining the transmission oil.</li> <li>2. Do ensure that the hydraulic strainer is cleaned at every schedule.</li> <li>3. Do adjust the top link for proper length.</li> <li>4. Do ensure that the lift cover bolts are always tight.</li> <li>5. Do keep the lower links in lifted position when the tractor is moving without an implement mounted on it.</li> <li>6. Do keep the ball joints on top and lower links clean and dry. Do not lubricate them.</li> <li>7. Do ensure that implements are raised and lower using the position control lever only and not the draft control lever.</li> </ol>	<ol style="list-style-type: none"> <li>1. Do not move the operational control range to fast response, while the tractor is on a hard surface like concrete, as the implement will crash down and get damaged.</li> <li>2. Do not attempt to pull or tow anything from the top link connection. It is dangerous.</li> <li>3. Do not use bolts place of lynch pins.</li> <li>4. Do not reverse the tractor with PTO driven implement attached and PTO lever in ground PTO position implement may get damaged in reverse.</li> </ol>

## 7. DO'S & DONT'S

DO'S	DONT'S
<b>BRAKING SYSTEM</b>	
<ol style="list-style-type: none"> <li>1. Do keep the brake pedals locked with interlocking latch when the tractor is not being used in field.</li> <li>2. Do use parking brakes when the vehicle is stationary.</li> <li>3. Do check loose connections in linkage mechanism.</li> <li>4. Do grease brake pedal bush, brake bracket connections.</li> </ol>	<ol style="list-style-type: none"> <li>1. Do not attempt to turn sharply using independent brakes when traveling at high speed. This may cause the tractor to overturn.</li> <li>2. Do not rest foot on the brake pedal.</li> </ol>
<b>FRONT AXLE &amp; STEERING MECHANISM</b>	
<ol style="list-style-type: none"> <li>1. Do lubricate the Bushes and steering drag links periodically.</li> <li>2. Do get the toe-in adjusted by an authorised service centre periodically.</li> <li>3. Do check the tightness of front and rear wheels recommended torque.</li> <li>4. Do flush oil once a year or 1000 hrs which ever is earlier. If tractor is not in operation.</li> </ol>	<ol style="list-style-type: none"> <li>1. Do not use wrong grade of oil for lubrication of steering gear box.</li> </ol>
<b>TYRES</b>	
<ol style="list-style-type: none"> <li>1. Do operate the tractor with correct tyre pressure. This will lead to better traction, longer tyre life and better fuel consumption.</li> </ol>	<ol style="list-style-type: none"> <li>1. Do not allow oil, grease and some crop spray containing considerable amounts of acid and alkalis to contaminate the tyre. These can cause considerable damage to the tyre if they penetrate into plies through small holes or splits</li> <li>2. Do not operate the tractor with excessive tyre pressure.</li> </ol>
<b>ELECTRICAL</b>	
<ol style="list-style-type: none"> <li>1. Do ensure that the battery terminals are kept clean.</li> <li>2. Do ensure terminal base is Lubricated with petroleum jelly.</li> <li>3. Do earth the tractor by wrapping a chain around the front axle, dropping one end of the chain on the ground.</li> </ol>	<ol style="list-style-type: none"> <li>1. Do not change leads of the battery terminals as this will lead to failure of electrical components.</li> <li>2. Do not leave the battery leads in the connected position if the tractor is not going to be used for a long period of time.</li> <li>3. Do not do any welding in the tractor without disconnecting Battery terminals.</li> </ol>

# 7. DO'S & DONT'S

## 7.2 DO'S & DONT'S

DO'S	DONT'S
<b>SAVE DIESEL</b>	
<ol style="list-style-type: none"> <li>1. Do switch off the engine when tractor is not in operation. Avoid unnecessary idling.</li> <li>2. Do operate at Optimum speed and correct gear.</li> <li>3. Do maintain the recommended tyre pressure for fuel efficient operation and long life of tyres. Check daily.</li> <li>4. Do use matching trailer for transportation. Ensure proper hitching. Never overload the trailer.</li> <li>5. Do maintain your tractor in good working condition.</li> <li>6. Do replace genuine parts from Authorised Dealers.</li> </ol>	<ol style="list-style-type: none"> <li>1. Do not allow fuel or oil to leak. Ensure that the joints are adequately tight.</li> <li>2. Do not spill fuel or oil while filling or topping up. Use funnel.</li> <li>3. Do not overfill engine oil as this can cause excessive oil consumption and oil leaks.</li> <li>4. Do not ride the clutch or brake pedal.</li> <li>5. Do not allow the rear wheel to slip. Use ballast, if necessary.</li> <li>6. Do not use worn-out tyres.</li> <li>7. Do not use inferior quality lubricants, use only recommended grade.</li> </ol>
<b>For Safe Operation</b>	
<ol style="list-style-type: none"> <li>1. Ensure that safety shields are in place and in good condition.</li> <li>2. Read all operating instructions before commencing to operate Tractor.</li> <li>3. Keep the air cleaner clean.</li> <li>4. Fit new sealing rings when the filter elements are changed.</li> <li>5. Watch the oil pressure gauge or warning light and investigate any abnormality immediately.</li> <li>6. Ensure that the transmission is in neutral before starting the engine.</li> <li>7. Keep all fuel in clean storage and use a filter when filling the tank.</li> <li>8. Attend to minor adjustments and repairs as soon as the necessity is apparent.</li> <li>9. Allow the engine to cool before removing the radiator filler cap and adding water, remove the radiator cap slowly.</li> <li>10. Shift into low gear when driving down steep hills.</li> <li>11. Latch the brake pedals together when driving on a highway.</li> <li>12. Keep draft control lever fully down when not in use.</li> </ol>	<ol style="list-style-type: none"> <li>1. Do not Run the engine with the air cleaner disconnected.</li> <li>2. Do not Start the tractor in an enclosed building unless the doors and windows are open for proper ventilation.</li> <li>3. Do not Operate the tractor or engine while lubricating or cleaning.</li> <li>4. Do not Temper with the fuel injection pump, (if the seal is broken) the warranty becomes void.</li> <li>5. Do not allow the engine to idle for a long period.</li> <li>6. Do not Use the independent brakes for making turns on the highway or at high speeds.</li> <li>7. Do not Refuel the tractor with the engine running.</li> <li>8. Do not Use the draft control lever for lifting of implements.</li> <li>9. Do not Start the engine with the PTO engaged.</li> </ol>

## 8. TROUBLE SHOOTING

### 8.1 Trouble Shooting

PROBLEM	POSSIBLE CAUSE	REMEDY
<b>ENGINE</b>		
<b>Engine not starting</b>	Wrong way of starting engine	Use proper way of starting
	No fuel	Check oil level
	Air trapped of fuel system	Bleed the fuel system
	Checking of fuel system	Contact your dealer
	Fuel injector faulty	Contact your dealer
	Fuel filter choke	Replace filter
<b>Engine not run in proper way</b>	Fuel filter choke	Replace filter
	Low quality of fuel	Drain diesel from tank and fill clean diesel
	Choking of fuel system	Check fuel system
	Fuel injectors faulty	Contact your dealer
<b>High oil consumption</b>	Oil level is more than maximum level	Keep oil level up to mark
	Oil quality is not good	Use genuine oil
<b>Engine not giving maximum power</b>	Leakage of oil	Check and repair
	Heavy load on engine	Decrease load or shift in low gear
	Air cleaner dirty	Clean air cleaner
	Fuel filter choke	Replace filter
	Engine overheating	Check cooling system
	Engine operating temperature is less	Check thermostat

## 8. TROUBLE SHOOTING

PROBLEM	POSSIBLE CAUSE	REMEDY
<b>Engine not giving maximum power</b>	Valve clearance not proper	Adjust through authorized dealer
	Throttle system not working properly	Check & repair through authorized dealer
<b>Engine abnormal noise</b>	Oil level less	Top up
	Oil pressure less	Check through authorized dealer
	Engine is overheated	Check and find reason
	Improper tappet setting	Adjust through authorized dealer
<b>Oil pressure gauge shows warning</b>	Oil level is less	Top up oil up to level
	Oil quality is not good	Use genuine engine oil
	Oil pump not working	Check and repair through authorized dealer
<b>Engine Over Heating</b>	Radiator cap faulty	Replace with new one
	Choked radiator fins	Clean it
	Engine gets overload	Decrease load or shift to low gear
	Oil level is less	Top up to level
	Coolant level is less	Check level and leakage of system and top up
	Slippage of fan belt	Check belt tension
	Thermostat faulty	Replace
	Choking of cooling system	Clean the cooling system
	Water temp. Gauge not working	Check through dealer and replace if faulty



## 8. TROUBLE SHOOTING

### 8.2 Trouble Shooting

PROBLEM	POSSIBLE CAUSE	REMEDY
<b>ENGINE</b>		
<b>High Fuel Consumption</b>	Air cleaner is dirty/choked	Clean air cleaner
	Overloading of engine	Reduce load or shift to low gear
	Improper valve clearance	Check and adjust
	Implement setting improper	Adjust it and take instructions from dealer for right option
	Less engine temp	Check injectors and service
	Fuel Injection nozzle faulty	Check and service through dealer
<b>HYDRAULIC</b>		
<b>Excessive Heating of Oil</b>	Improper inflation pressure	Check and adjust according to specified
	Oil level is high or less	Check and maintain proper level
	Hydraulic filter element choked	Replace
<b>Linkage Goes Down Slowly</b>	Mechanical linkage may faulty	Contact your authorized dealer
	Bush tight	Contact your authorized dealer
<b>Linkage Not Lift Fully</b>	Response valve setting improper	Contact your authorized dealer
	Improper lift arm setting	Contact your authorized dealer
	Improper internal adjustment	Contact your authorized dealer
<b>Three Point Linkage Not Respond To Lifting While Operating Hydraulic Lever</b>	Linkage connection not joint properly	Contact your authorized dealer
	Heavy load on linkage	Contact your authorized dealer
<b>Draft Control Fast</b>	Draft/position control setting wrong	Contact your authorized dealer
	Implement not working well	Make correct adjustment of implement

## 8. TROUBLE SHOOTING

PROBLEM	POSSIBLE CAUSE	REMEDY
<b>Hydraulic System Not working properly</b>	Response valve setting very low	Check valve by your dealer
	Oil level low	Check and top up
	Hydraulic filter choked	Replace filters
	Hydraulic system faulty	Check through authorized dealer
	Hydraulic pump not working	Contact your authorized dealer
<b>Draft Control Fast</b>	Draft/position control setting wrong	Contact your authorized dealer and check system
<b>BRAKES</b>		
<b>Brakes Noisy</b>	Wrong adjustment of brakes	Check
<b>While Applying Brakes Tractor is Going in One direction</b>	Both brakes are not set properly	Adjust
<b>Brakes Works When Fully Pressed</b>	Wrong adjustment of brake pedal	Check and Adjust

### 8.3 Trouble Shooting

PROBLEM	POSSIBLE CAUSE	REMEDY
<b>ELECTRICAL</b>		
<b>Electrical System Not Working</b>	Battery terminal(s) loose or rusting of terminal(s)	Clean and tight the terminals
	Less specific gravity of battery	Replace or fill electrolyte up to level
<b>Starter Motor Not Working</b>	Battery terminal loose	Tightened
	Battery discharged fully	Recharge or replace battery
	Faulty starter motor	For repair contact your dealer
<b>Battery Not Charging</b>	Loose or rusted terminals	Clean and tight terminals
	Belt loose	Check belt tension
	Faulty battery	Replace



# INDEX

---

## A

Acceleration Control	4-93
Adjusting Rear Wheel Track	4-105
Adjusting The Maximum Steering Angle for 4WD Axle	4-107
Alternator	5-141
Auto Lift	4-119
Auxiliary Circuit (2DA/3DA)	4-116
Avoid contact with Agricultural Chemicals	2-51
Avoid Hot Exhaust	2-46

## B

Ballasting the Front Axle	4-107
Ballasting with water for Rear wheels	4-108
Battery	3-84
Battery and its Maintenance	5-140
Block Heater (Optional)	3-88
Boarding The Tractor	4-90

## C

Cabin Plate (D)	1-17
Chassis Serial Number (A) Cabin	1-17
Chassis Serial Number (A) Platform	1-16
Check the Tractor	2-28
Clean the tractor	2-29
Cleaning of Suction Strainer	5-138
Clutch Pedal	4-94, 5-135
Cold Weather Starting, Temperature Below 0° C (32° F)	4-92
Combination Switch (Lighting, Turn Signals, Horn Control Lever)	3-81

## D

Dashboard Controls (Platform/Cabin Tractor)	3-68
Differential Lock	4-104
DO'S & DONT'S	7-147, 7-150
DPF System	3-82
Driver's Seat	3-89
Dual Air Trailer Brake (Optional feature)	4-102

## E

Engine	4-91
Engine Oil Level	5-129
Engine Serial Number (B) Cabin	1-17
Engine Serial Number (B) Platform	1-16
Exhaust ATS	4-94

## F

Follow recommended starting procedures	2-32
Follow safe operating practices	2-34
Foot Brake Pedals	5-135
Forward/Reverse Lever	4-96
Four Wheel Drive (4WD) Operation	4-119
Front Loader Mounting Points	4-121
Fuel Tank Filling	5-127
Fuse Boxes for Cabin Tractor	3-79
Fuse Boxes for Platform and Cabin	3-79
Fuse Boxes for Platform Tractor	3-80

## G

Gear Change Levers	4-95
Gear Speed Lever	4-95
General Maintenance of Electrical System	5-139
General operating hazards	2-40
Greasing Points	5-143
Ground Speeds	4-104

## H

Handle fuel with care	2-46
Hitching Implements	4-109
Hydraulic Controls Operations	4-115
Hydraulic Trailer Brake (HTB) (Optional feature)	4-103
Hydraulic Valve Adjustment	4-118

## I

If You Move	2-21
Ignition (Starting) Switch	3-74
Inspection of Hoses	5-139
Instrument Panel	3-59
Introduction	2-19

## J

Jack Up the Tractor - Lifting Points	4-122
--------------------------------------	-------

## K

Know Your Equipment	2-27
---------------------	------

## L

Leaving The Tractor	4-90
Limited Use in Forestry Operation	2-51
Long Idle Period	5-142

---

# INDEX

---

<b>M</b>		Roof Mounted Control Panel for Cabin Tractor	3-75
Maintenance of Air Cleaner (Dry)	5-128	Roof Mounted Switch (Cabin Tractor)	3-69
Make the right moves	2-33	Roof Mounted Switches for Cabin Tractor	3-73
Marching the Tractor	4-92	ROPS Certificate Plate (D) Platform	1-16
Matching Implements	6-146	Routine Maintenance Table	5-123
<b>N</b>		Running in	4-92
Noise & Vibration Levels	2-52	<b>S</b>	
<b>O</b>		Safely Handling Batteries	2-45
oad regulations	2-42	Safety	2-21
Oil and Lubrication Chart	5-144	Safety Alert Symbols and Terms	2-22
Oil Changes for Transmission, Rear Final Drives and Power Lift Hydraulic Circuits	5-137	Safety Frame	2-25
Oil Changes in 4WD Front Axle (optional feature)	5-136	Safety from Lightning Strike	2-51
Opening The Bonnet	4-91	Safety Labels & its Position on Tractor	2-52
Operator Presence Control (OPC)	4-90	Safety Structure (ROPS)	4-117
<b>P</b>		Safety while Operating Loader attachments	2-50
Parking Brake	4-101	Safety-After Operation	2-42
Parts Warning	2-20	Safety: A word to the Operator	2-23
Power Steering Reservoir Oil Level	5-134	Safety: Danger, Warning and Caution	2-23
Power Take-Off	4-97	Safety: Decals	2-24
Protect the environment	2-30	Safety: Follow A Safety Program	2-24
PTO Lever	4-96	Safety: Introduction	2-22
PTO Safety	2-47	Safety: Prepare For Safe Operation	2-26
PTO Speed Selection (A)	4-98	Safety: Servicing The Tractor	2-30
<b>Q</b>		Safety: Starting	2-31
Quick Attach Three Point Linkage and Ladder Hitch with Clevis (Optional Feature)	4-110	Safety: Work Safety	2-33
Quick-Coupling (Hook-Type) Draft Links	4-111	Service After Warranty	2-21
<b>R</b>		Service Brake	4-101
Radiator	5-132	Service Record	8-155
Range selector lever	4-95	Seven Pin Rear Socket for Trailer	3-84
Registration Plate (B)	3-85	Starter Motor	5-141
Replacement of Engine Oil & Engine Oil Filter	5-129	Statutory Plate (C) Cabin	1-17
Replacement of Spin-on Fuel Filter	5-131	Statutory Plate (C) Platform	1-16
RH Fender Mounted Controls Switch (Cabin Tractor)	3-69	Stopping the Tractor	4-94
RH Fender Mounted Controls Switch (Platform Tractor)	3-68	<b>T</b>	
Risk of overturning	2-35	Technical Specifications	6-145
Risks deriving from exposure to noise	2-43	Three Pin Rear Socket	3-84
Road Transport	2-41	Three-point Linkage	4-114
		Tilt and Telescopic Steering	3-88
		To avoid rear overturns	2-37
		To avoid side overturns	2-36
		Tool Box (C)	3-85
		Top Link Attachment to Rocker Base	4-116
		Tractor Controls (Platform/Cabin Tractor)	3-58
		Tractor Identification	1-16
		Tractor Identification — Cabin	1-17
		Tractor Lights (Cabin Tractor)	3-87
		Tractor Lights (Platform Tractor)	3-86
		Tractor Transport	4-120

---

# INDEX

---

Transmission / Hydraulic Oil Filter (3)	5-134	Use all Available Protective Devices	2-28
Trouble Shooting	8-151, 8-153–8-154	Using this Operator Manual	1-15
Turbo Engine	4-91		
Turning off the Engine	4-94		
<b>U</b>			
Unhitching Implements	4-110	Warranty Procedure	2-20
Universal Symbols	1-18	Warranty, Pre—delivery and Installation	2-20
USB Socket (D)	3-85	Watch out for others	2-34
		Wheels and Tyres	4-106

---